

World Transport Policy and
Practice
Volume 21.4
February 2016



ISSN 1352-7614

© 2016 World Transport Policy and Practice

PROFESSOR JOHN WHITELEGG
STOCKHOLM ENVIRONMENT INSTITUTE AT
YORK,
UNIVERSITY OF YORK,
YORK,
YO10 SYW, U.K

EDITORIAL BOARD

PROF. DR.-ING. HELMUT HOLZAPFEL
ZENTRUM FÜR MOBILITÄTSKULTUR KASSEL
DÖRNBERGSTR. 12
34119 KASSEL
WWW.MOBILITAETSKULTUR.EU
Tel: 0049-561-8075859

ERIC BRITTON
MANAGING DIRECTOR,
ECOPLAN INTERNATIONAL,
CENTER FOR TECHNOLOGY AND SYSTEMS
STUDIES,
9, RUE GABILLOT
69003 LYON, FRANCE

PAUL TRANTER
SCHOOL OF PHYSICAL ENVIRONMENTAL &
MATHEMATICAL SCIENCES,
UNIVERSITY OF NEW SOUTH WALES,
AUSTRALIAN DEFENCE FORCE ACADEMY
CANBERRA ACT 2600, AUSTRALIA

PUBLISHER

WORLD TRANSPORT POLICY AND PRACTICE,
41 CHURCH ST,
CHURCH STRETTON,
SHROPSHIRE
SY6 6DQ
TELEPHONE +44 (0)1694 722365
E-MAIL:
john.whitelegg@sei-international.org
WEB:
<http://worldtransportjournal.com>

CONTENTS

	PAGE
Editorial	3
Abstracts and Keywords	5
Semester Tickets for University Students in Germany: A Success Story for 25 Years <i>Miriam Müller</i>	7
Leveraging collective action for a seat-belt wearing intervention in Afyonkarahisar, Turkey <i>Huseyin Akbulut, Serap Sener, Fatih Vursavas and Meleckidzedek Khayesi</i>	19
Will the government's spending on expanding the national road network deliver anything useful? Have they properly taken into account induced traffic and extra congestion likely to be caused elsewhere? <i>John Elliott</i>	37
Streets of yesterday, today, and tomorrow <i>Joseph Kott</i>	42
The Public City. Essays in honour of Paul Mees edited by Brendan Gleeson and Beau B Beza, Melbourne University Press, 2014. ISBN 9780522867305 <i>Reviewed by John Whitelegg</i>	52

EDITORIAL

India has been in the news a lot in recent months mainly for its poor air quality, deaths and injuries on the roads and the serious damage this does to quality of life, family life and the economy. In the 23 years of WTPP we have not carried enough material by Indian authors and want to use this editorial to encourage more submissions from that country. We would like to explore the underlying factors that have produced such a large loss of life and decline in quality of life and also to explore the links between transport and poverty alleviation. We know that there are some very impressive projects underway e.g. to assist rickshaw pullers and pedallers to secure a better income and provide an enhanced and invaluable transport choice. We know that Kolkata has one of the world's oldest tram systems, a metro, an urban railway and river ferries but we hear very little about how these assets are being put to use to encourage higher levels of use and lower level of car use. We hear about the abolition of diesel fuelled vehicles and car rationing by odd/even number systems in Delhi but we don't know how effective these have been. We also hear very little about pedestrian and cyclist facilities in Indian cities and the contribution they can make to air quality, reducing congestion and alleviating poverty. So please contact us!

I have always thought of India as a splendid example of rich community life, supported by highly accessible activities and

destinations in its cities and an eclectic mix of low cost transport choices to bring people into contact with other people and the destinations they need to reach. On several visits to Kolkata over 10 years ago I was amazed at the richness of what I could do, see and buy on the streets and the number of attractive shops, businesses, tea stands and restaurants was very impressive indeed. Of course the picture is more complicated than this with huge problems of death and injury in the road traffic environment, overloaded and unpleasant conditions on buses, underfunded trams (in the case of Kolkata) and severe air pollution. These problems were there in the 1980s but they are now getting a lot worse and at an increasing rate.

In my mobility book I discuss India in some detail. These are short extracts on the growth of mobility, decline in walking, cycling and public transport, deaths from air pollution and deaths on the roads. For more details and for original sources please refer to Chapter 13 of "Mobility".

- India's private motor vehicle market (motorised 2-wheelers and cars) grew by more than 85% between 2003 (around 59 million vehicles) and 2009-10 (around 110 million vehicles) at an average annual growth rate of 11%
- Public transport mode share declined in Indian cities between 1994 and 2007
- Modal share for non-motorised transport (walking and cycling) declined

	2004	2008
China	356,664	470,669
India	140,937	168,601

Mortality associated with outdoor air pollution in China and India

Source: <http://apps.who.int/gho/data/view.main.100320>

	China	India
Official National Statistics	65,225	130,037
Global Burden of Disease Estimate	283,000	274,000
% Under-reporting	334	111

Under-reporting in official statistics of road traffic deaths in China and India, 2010

Source: World Bank (2014)

in all Indian cities. Cycling modal share has come down from an average of 30% in 1994 to less than 11% in 2007, attributable to an increase in trip length as a result of urban sprawl, inadequate facilities for cycling and growth in private motor vehicle ownership and use

The growth in car ownership and use and the transformation of land that could grow a lot of food for India's urban millions is a very serious problem. Cities spread out, food growing potential declines, the urban poor and not-so-poor suffer a degraded environment with more noise, stink and danger and ugly flyovers and the daily stress of trying to cross roads or cycle to nearby destinations. This is the central problem in the global and Indian mobility crisis addressed in my new book "Mobility" (details below). Indian politicians have fallen into line with the poor example set by US, European and Australian governments and have allocated huge amounts of money to roads, flyovers and motorways all of which add very little to the quality of life of millions of India's citizens and indeed make it much worse. Billions of dollars spent on moving one tonne of metal around a crowded city is poor quality physics, a major public health problem and mops up a great deal of public money that could be spent on schools, health care, buses, local trains, walking and cycling facilities.

As a European, so-called sustainable transport expert, it is not for me to criticise India and the way that transport spending and its outcomes impacts on over a billion people. There are excellent commentators on India in India. It is however the global problem that concerns me and there is a need for all of us on this beleaguered planet to speak out say "Enough! This is not right". So I want to suggest that in India those involved in policy debate and how Indian public funds are spent engage with some radical, original thinking and tell us all if they are doing this already. India does not have to follow the discredited model pursued by USA or UK. It can strike out on its own intelligent and truly democratic path. On the assumption that India and the global community wants to eliminate death and injury in road crashes and believes in social justice so that we can do things correct a system that is pun-

ishing older people, women and children then we need to do a very small number of things everywhere on this planet and India can take the lead. The specific things that can be done include:

- Every road and every street in every town and city must have a 2-meter wide pedestrian pavement on either side that is well maintained and is higher than the street level so that vehicles cannot stray into people space.
- This also applies to rural areas where it is known that people walk or cycle along a highway that carries trucks and buses and these large vehicles bring danger in their wake
- Crossing points. All roads need safe crossing points for pedestrians. There are a number of ways of doing this but a low cost option is a raised "table" so that the pedestrian can walk across a surface that is higher than the road surface and a vehicle must slow down to cope with the vertical displacement.
- Huge improvement in bus services (vehicle quality, emissions, driver and conductor training, overcrowding). This will need investment but nothing like the scale of investment for highways and flyovers. Bus Rapid Transit (BRT) is also a good idea on principal routes and corridors. Special attention has to be given to safety and security of women.

Like all other countries on the planet India has to make choice. It can either go along with the mobility fetish (more roads, flyovers car parks) and very little attention to the needs of people who walk, cycle or take a bus or it can go truly democratic and ethical and introduce changes that benefit all ages, both genders and ordinary everyday trips that citizens of every level of income need to make. My guess is that India's citizens prefer the ethical option and something that is fair and kind to children and older people. We will see.

John Whitelegg
Editor

Semester Tickets for University Students in Germany: A Success Story for 25 Years

Miriam Müller

Abstract:

'Semestertickets' are a special tariff for university students in Germany to use public transport, financed in solidarity by the students. The article describes the concept of semester tickets, their development over the time, especially regarding their extended reach, and presents selected results on usage, acceptance and their effects on mobility behaviour and car ownership of students.

Keywords: Semester tickets, student mobility, public transport, tariff, mode shift, sustainability, Germany.

Leveraging collective action for a seat-belt wearing intervention in Afyonkarahisar, Turkey

Huseyin Akbulut, Serap Sener, Fatih Vurvas and Meleckidzedek Khayesi

Abstract:

Drawing on Elinor Ostrom's concept of action situation, this paper examines how actors occupying different positions mobilized, interacted and negotiated several issues to implement a seat-belt intervention in Afyonkarahisar in Turkey. A key principle the actors agreed upon was the importance of subjecting all members of society to the same traffic laws, regardless of class or income. Seat-belt wearing rates increased from 3.9% to 36.8% in Afyonkarahisar over a five-year period of an intervention project. The experience gained in Afyonkarahisar was used to strengthen planning of a similar initiative in Ankara. The project also contributed to sealing gaps in road traffic law, especially regarding seat-belt wearing. The process went beyond the regulations on seat-belt wearing and speed, which were the focus of the project, to addressing gaps on several other aspects in the traffic law. An unexpected outcome was that interventions in seat-belt wearing and speed management were spread from the initial two pilot

sites (Afyonkarahisar and Ankara) to two other provinces (Antalya and Kocaeli) and to all the 81 provinces of Turkey. This expansion followed a circular from the Prime Minister in 2012 requiring all the provinces to implement these measures. This study concludes that sustained transactions with and among different gatekeepers is necessary to keep making appropriate decisions and taking actions on road safety policy within different institutions and administrative jurisdictions going. This experience contrasts a general perception that road safety measures are simple and low-cost, likening them to a low-hanging fruit.

Keywords: Action situation, knowledge translation, knowledge sharing, collaboration, actors, decisions, intervention, seat-belt, road traffic safety, Afyonkarahisar, Turkey

Will the government's spending on expanding the national road network deliver anything useful? Have they properly taken into account induced traffic and extra congestion likely to be caused elsewhere?

John Elliott

Abstract:

In this paper John Elliott reminds us of earlier studies which have shown the consequences of past reviews of induced traffic and traffic reductions from expanding or contracting road space. The government seemed keen on evidence based strategies and policies and it now seems opportune to reiterate some of the hard and not quite so hard evidence available. It should be added that the core of this evidence has been given to government from 1985 onwards by the author and others; the first evidence of the extent of generated or induced traffic from roadbuilding dates from the 1920s but has appeared from various studies at regular intervals since.

Many of the road schemes being proposed by the UK government in 2015 are in the vicinity of cities and conurbations in places where it is recognised that there is serious congestion. However all the evidence suggests that that additional road construction especially anywhere near such

major urban areas is unlikely to help traffic conditions or the economy.

Pollution and environmental aspects of the government's road policies are not discussed but are possibly an equally strong reason to challenge the present policies.

Key words: induced traffic, newly generated traffic, transport policy and traffic generation, road building, strategic road programme

Streets of yesterday, today, and tomorrow

Joseph Kott

Abstract:

The street connects us to the wider world and is a venue for many of life's activities. This combination of linkage and destination makes the study of streets compelling and important. Streets foster social and economic life in cities. Streets also meet the need for movement. The task of street planning and design is to balance these demands. Located at the juxtaposition and responding to dynamic systems of transportation, land use, and human behavior, streets themselves will not remain static. The study of streets is therefore an inquiry into the evolution of cities and their inhabitants. The task of contemporary practice in street planning and design is to guide this evolution toward more sustainable outcomes. This article concludes with an exploration of best practice in creating more sustainable streets.

Keywords: sustainable streets, street design, multimodal streets, placemaking, livable streets

Semester Tickets for University Students in Germany: A Success Story for 25 Years

Miriam Müller

1. Introduction

The so-called 'Semesterticket' is a special tariff for university students in Germany which enables them to use public transport in the area of their university. Semester tickets are financed in solidarity by the students: If a university runs a semester ticket, all students automatically have to buy a ticket for one semester (6 months), regardless of whether they want to use public transport or not. In return, the students can use public transport in the area of their university for a very low semester contribution as much as they want without purchasing any extra tickets. In Germany, the first semester ticket was introduced 25 years ago in Darmstadt (1991) as a result of student initiatives. Today, most German universities run a semester ticket.

This article describes the concept of semester tickets in Germany, their development over the time and presents empirical research data on student acceptance and the effects of semester tickets on mode shift to public transport and the reduction of car ownership.

2. Concept of semester tickets

Semester tickets are a special tariff for university students to use public transport, which are financed in solidarity by the students: All students of a university have to pay an obligatory solidary contribution and automatically receive a public transport ticket for 6 months. The concrete design of a semester ticket can vary considerably from university to university, depending on the specific conditions agreed on with the public transport associations. Semester tickets differ regarding their area of validity (for example only for buses within a city or for all means of public transport in a state), prices, free carriage of a bicycle or an additional person, the possibility to use high speed trains, hardship regulations or the inclusion of public bike sharing systems in recent years (see table 1).

The responsible bodies for the contractual agreement of a semester ticket are either

the constituted student bodies ('Verfasste Studierendenschaft') or student services ('Studentenwerk') of a university and the public transport association in the area of the university. The constituted student bodies and the student services are the legally responsible corporate body or public agency, which fulfil their legally imposed obligations to provide economic, social, health and cultural support to university students¹. Since students are members of these bodies or public agencies, constituted student bodies and student services have the legal right to collect contributions from the students, also for mobility purposes. The introduction of semester tickets is normally legitimized by taking a vote among the students of the respective university on whether a semester ticket shall be introduced regarding the conditions offered by the public transport association or not.

In the year 2000, the Federal Constitutional Court of Germany confirmed the lawfulness of collecting solidary contributions for semester tickets from students after a student had sued the obligation to pay this contribution. According to the judgement, student bodies and student services have the legal right to collect contributions for semester tickets because the provision of semester tickets is a reasonable social and economic service for students during their needy time of university education. The judges did not see a problem in the fact that semester tickets might not be used by all students, because the advantages of semester tickets that can be obtained for the entire student body outweigh their disadvantages, as it can significantly reduce the costs for travelling to university. Furthermore, the judges pointed out that the financial burden for the students was acceptable, because discounts of more than 75% compared to regular tickets can be obtained and significant improvements of the local traffic, parking and environmental conditions can be achieved (BVerfG, 1 BvR 1510/99, 2000).

2.1 Price formation

The formation of the semester ticket price is a complex process, as there is exactly

¹ § 53 Hochschulgesetz (HG) NRW and § 2 Studentenwerkgesetz (StWG)

one provider (transport company) and one customer (student representative). Thus, the price can not be determined in a regular business competition as it is determined for conventional goods (Preistrup, Stingel 2007: 386). At the same time, there are diversified preferences and willingnesses to pay solidary contributions by the students, which need to be considered in order to avoid the risk of losing student acceptance for paying a contribution for semester tickets (ibd.). For transport companies, the introduction of a semester ticket may imply extra costs, if service offers need to be expanded due to additional travel demand. On the other hand, transport companies may grant price reductions for semester tickets because of quantity discounts and reduced administrative expenses.

In general, the final price of a semester ticket (see figure 1) ranges between an upper price limit, which can be defined on the basis of empirical data regarding student mobility patterns and their willingness to pay for a solidary contribution, and a bottom price limit, which can be defined by an opportunity cost analysis determin-

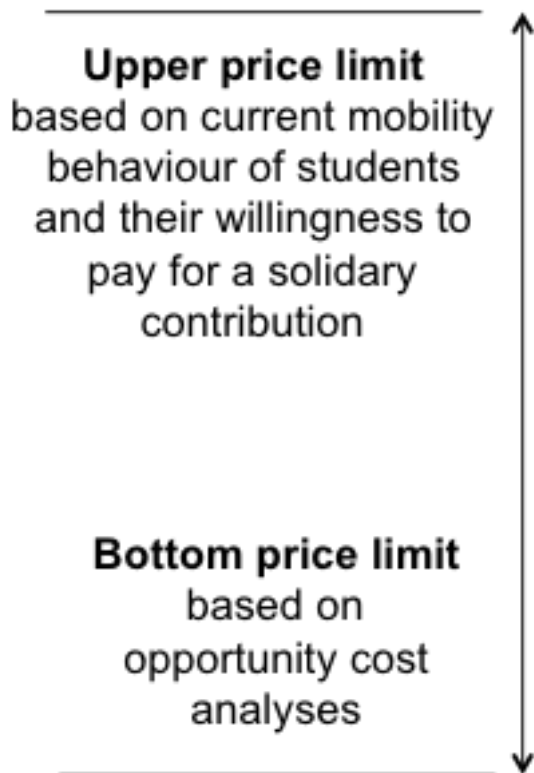

Figure 1: Price formation of semester tickets

ing the revenues that would be achieved if no semester ticket would exist (ibd.: 391).

2.2 Solidary Model and Base Model

There are two different semester ticket concepts in Germany – the so-called ‘solidary model’ and the ‘base model’ (see figure 2). For the solidary model, all students have to pay an identical obligatory solidary contribution and automatically receive their semester ticket which enables them to use public transport in the area of validity. For the base model, all students have to pay an identical reduced obligatory solidary contribution as a basic funding. Because of the reduced price, students receive either no access or only a very limited access to public transport, mainly limited to off-peak hours. If they wish to use

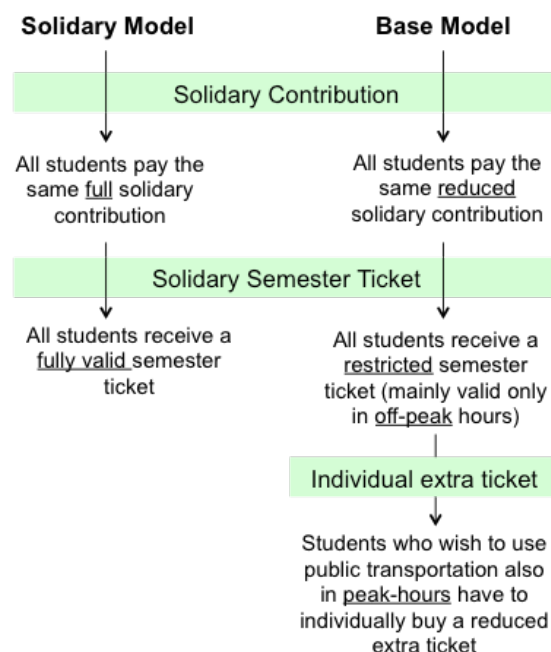

Figure 2: Solidary and base model semester tickets

public transport without any restrictions, they individually have to pay an optional extra fee.

In Germany, most semester tickets are solidary models. Solidary models mainly exist if the contract for a semester ticket is signed between a public transport company and the so-called ‘Verfasste Studierendenschaft’ (constituted student body). The broadest dissemination of base models can be found in the Federal States of Baden-Württemberg and Bavaria (Reut-

ter & Müller 2015: 6). This is because in the Federal State of Bavaria, constituted student bodies were abolished in 1973 and in Baden-Württemberg they were re-introduced only in 2012. Thus, especially in these regions, the contractual partner for semester tickets are student services ('Studentenwerke'). Student services try to keep their risk of liability low and thus prefer to sign base model contracts because the solidary contribution which students are obliged to pay is lower than for solidary models.

There are advantages and disadvantages for both solidary and base model. The advantage of the solidary model is that students immediately profit from their solidary contribution and can use public transport without any restrictions. Thus, the incentive to use public transport is higher for a solidary than for a base model. Furthermore, solidary models can be offered for a cheaper price compared to a base model which consists of a solidary contribution plus an extra fee, because solidary semester tickets are more attractive for transport companies as transport companies receive assured revenues and administrative costs are lower. In a base model semester ticket, the obligatory solidary contribution for students is lower than in a solidary model and thus student preferences on whether they want to use public transportation or not are more respected than in a solidary model.

3. Development of semester tickets

Since their first introduction, many semester tickets have undergone a remarkable development, especially regarding their area of validity. At many universities, the geographical reach of semester tickets was increased impressively over the course of time, for example at the universities in the Federal State of North Rhine Westphalia (NRW). At the beginning, many semester tickets were valid only in the city area surrounding a university. In regions where student representatives joined forces, semester tickets with a larger geographical reach could be negotiated with public transport authorities, for example in the Ruhr Metropolitan Area, where the first semester ticket covered the entire transport network of the Rhein-Ruhr Transport

Association (VRR) including 20 universities (Schreiber 1996: 33). As a next step, student representatives of the universities in the state of North Rhine-Westphalia (NRW) joined forces and negotiated a state-wide valid semester ticket: Since 2008, most students in NRW can use public transport in the entire state (including cities like Bonn, Cologne, Düsseldorf, Ruhr area, Münster) for approximately 25 to 30 Euro per month.

Similar developments can be observed in other German states, where semester tickets enable students to be mobile in the entire state (some universities in the Federal States of Hesse, Brandenburg, Saarland). Also the Federal States of Thuringia, Saxony and Lower Saxony have introduced state-wide valid semester tickets. However, only trains can be used if students exit the validity area of the city of their university or the respective transport network. Students in Rhineland-Palatinate and Saarland are working on a semester ticket which is valid in both federal states. On the other hand, the introduction of a state-wide valid semester ticket in Schleswig Holstein was rejected by the students in a vote because many students considered the ticket offer to be too expensive.

The tariff structure of the public transport system is a crucial factor for designing an attractive semester ticket offer. The less scattered and the more integrated tariff structures in a region are, the easier the implementation of a far reaching semester ticket is: In the state of Hesse, there are only two transport associations which facilitated the implementation of a state wide valid semester ticket. The 'NRW-Tarif' in NRW, a state-wide tariff for local and regional public transport since 2005, facilitated the realization of the state-wide valid semester ticket in NRW. However, even with integrated tariff structures, the technical realisation of a semester ticket can still differ from university to university like in NRW, where various kinds of different tickets exist (paper ticket, print ticket, e-ticket, chip on student card), depending on the specific framework conditions of the respective universities.

	Introduction	Price	Range	Additional services included
University of Darmstadt	1991	117 €/semester (19.50 €/month)	Public transport network Rhein-Main-Verkehrsverbund (RMV)	60 free minutes for using the bike sharing system of Deutsche Bahn since 2014 (costs: 2.38€/student/semester); free bicycle carriage; option to purchase reduced tickets for neighbouring transport networks.
University of Cologne	1993: local/ regional validity 2008: extension to state-wide validity	168 €/semester (28 €/month)	All means of local and regional public transport in the Federal State of North Rhine Westphalia (18 million inhabitants)	Only in the region (not state-wide): free carriage of a bicycle; after 7 pm and at weekends: free accompaniment of another person and three children 6-14 years.
University of Leipzig	1996	114.50 €/semester (19 €/month) (base model until 2014, now solidarity model)	Public transport network Mitteldeutscher Verkehrsverbund (MDV)	Semester contribution includes 1.50 €/student/semester for mobility funds offering a do-it-yourself repair shop, reduced carsharing fares, transporter rental, 30 free bike sharing minutes for foreign students.
University of Passau	2013	16 €/semester (2.70 €/month)	Buses in the city of Passau (51 000 inhabitants)	-
University of Munich	2013	Solidary contribution: 59 €/semester (9.80 €/month) for off-peak hours; Optional: additional 147 €/semester (24.50 €/month) for peak hours	Public transport company of Munich (City of Munich and surrounding municipalities, 1.4 million inhabitants)	-
Westfälische Hochschule, Campus Bocholt	No semester ticket, because students voted against the introduction of a semester ticket at their campus. One main reason given for rejection was the insufficient connection of their campus to the public transport network.			

Table 1: Comparison of selected semester ticket concepts at German universities

Whereas in Germany some semester tickets were introduced a long time ago and now cover a wide validity area, there are also a few universities where semester tickets still do not exist, where they have been introduced only recently or where the geographical reach is very limited. For example, the semester ticket at the University of Passau has existed since 2013, costs only 16 Euro per semester (2.67 Euro/month)² and can be used only for buses within the small city of Passau (51 000 inhabitants). In Munich, the first semester ticket was introduced in 2013 as a base model. All students have to pay 59 Euro per semester (10 Euro/month) which enables them to use public transport in off-peak hours (1800 to 0600) and at weekends. If students wish to extend validity to peak hours, they have to pay an individual extra fee of 147 Euro per semester (24.50 Euro/month). The following table gives an overview of the different forms semester tickets can have in Germany.

In recent years, some public transport companies started initiatives to increase the price of their semester tickets noticeably. For example, the VRR in the Ruhr Metropolitan Area terminated their contract with student bodies in 2015 and offered a new semester ticket contract including a price increase of about 43% for the time period 2015 to 2019 (Blickfeld 2014). The reasons given for price increases were an increased proportion of students using the ticket and increased distances travelled by the students, according to VRR evaluations (VRR 2013). The termination of semester ticket contracts in the VRR area was followed by student protests against rising prices, however there was no option to diminish the intended price increases. Thus, additional votes among students were taken on whether to accept price increases or to reject semester tickets at all. In the end, students from all universities in the VRR area decided to keep their semester tickets and to accept the price increases in the upcoming years.

4. Empirical evidence on the acceptance and effects of semester tickets

4.1 Introduction of semester tickets in the 1990s

The introduction of semester tickets in Germany had a significant effect on the mobility patterns of students in Germany. Several studies analysed the effect of semester tickets on mode choice of students on their way to university. Blee et al. (2001: 31) demonstrated for the universities in Darmstadt a mode shift on trips to university between 1991 and 1999 due to the introduction of semester tickets with an increase in public transport use (17% to 42%), a decrease in car use (46% to 28%) and a decrease in walking and cycling (37% to 29%).

Similar effects could be demonstrated for the University of Cologne (Kling et al. 1996), where a wide approval for semester tickets could be demonstrated (70% rated the semester ticket as 'good' and 'very good'). The new mobility options also had an influence on the residential location of students, reducing the share of students living up to 10 km from the university from two thirds in 1991 to 50% in 1999 (Blee et al. 2001: 32). According to a model calculation, passenger kilometre for travelling to university thus rose by 16.5% with a decreasing share of car use and an increasing share of public transport use (ibd.).

4.2 Extension of semester tickets in recent years: NRW semester ticket

The most recent evaluation of semester tickets analysed the use, acceptance and effects of the extension of semester tickets from regional to state level. Müller (2010) analysed the extension of the regional semester at the University of Bielefeld, covering the region Ostwestfalen-Lippe, to the entire state of North Rhine-Westphalia (NRW) (see figure 3).

Since 2008, the universities of NRW have the option to extend the geographical reach of their regional semester tickets to state level by purchasing an extra semester ticket ('NRW Semesterticket'). Both regional and NRW semester tickets are

2 Winter semester 2015/16

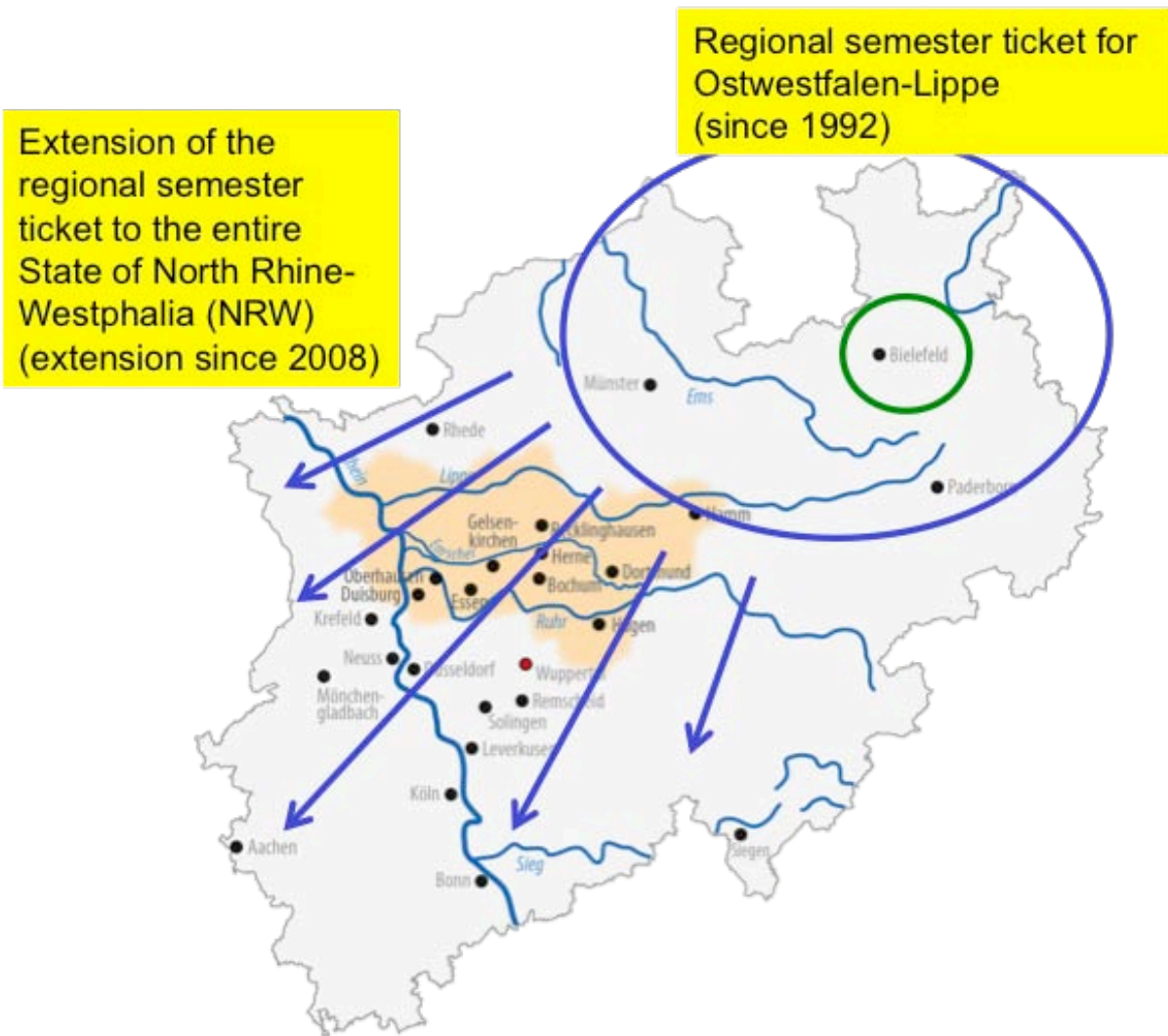

Figure 3: Extension of the semester ticket at the University of Bielefeld from regional to state level (North Rhine-Westphalia) in 2008

designed as solidary model semester tickets. Whilst the prices and conditions of the regional semester tickets can vary within NRW, the price and conditions of the extension to state level are the same for all universities. At the university of Bielefeld, the regional semester ticket for Ostwestfalen-Lippe currently costs 120 Euro for 6 months plus additional 48 Euro for the extension to state level (in total 28 Euro per month). All means of local and regional public transport in NRW can be used with the NRW semester ticket, covering an area of 34 000 km² and 29 cities with more than 100 000 inhabitants. Today, 90 university campuses have introduced the NRW semester ticket at their universities. Thus, more than 500 000 university students can be mobile with public transport within the entire state of North-Rhine Westphalia.

Evaluation Methodology

For evaluating the NRW semester ticket, an online survey among the 17 458 students of the University of Bielefeld was conducted in 2010 by email invitation. Exactly 4 500 students participated in the survey (return of 26%). The online survey evaluated usage, acceptance and effects of the extension of the regional ticket to state level.

Usage and acceptance of the NRW semester ticket

Whereas studies on the introduction of semester tickets mainly focused on student mobility on their way to university (see section 4.1), the study on the NRW semester ticket explicitly focused on the extension of the geographical reach of semester tickets (for all trip purposes).

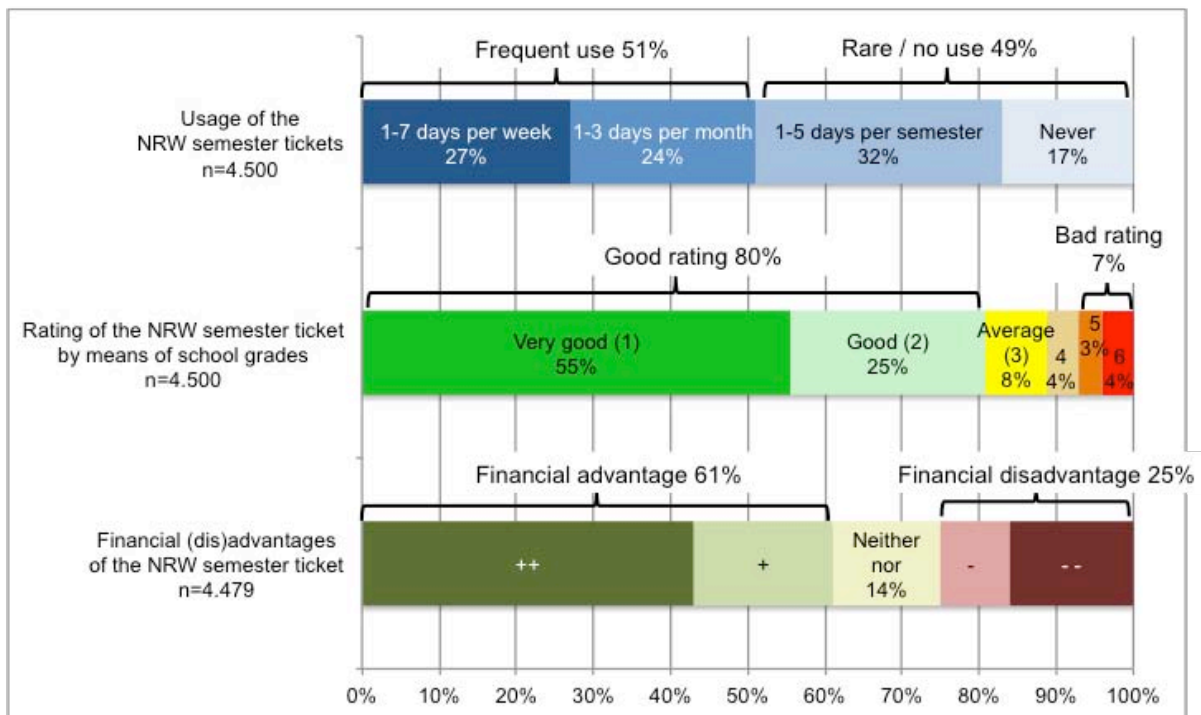

Figure 4: Usage, acceptance and financial implications of the extension of the semester ticket from regional to state level by the NRW semester ticket* at the University of Bielefeld (2010)

The online survey at the University of Bielefeld demonstrated that the extended reach of the semester ticket from regional to state level is frequently used by about half of the students (see figure 4). The other half uses the geographical extension of their ticket never or hardly ever.

As the third bar demonstrates, for 25% of the students the extension on state level means a financial disadvantage, for 61% the NRW semester ticket means a financial advantage. But although half of the students never or hardly ever makes use of the new mobility options and for one quarter the extension of the semester ticket to state level means a financial disadvantage, most students rate the NRW semester ticket as good or very good (80%, second bar).

Reasons for the high acceptance of the NRW semester ticket are solidary aspects ('Many students profit from the extension and depend on it'), the cheap price, the option to use the ticket one day the students might need to, flat rate preferences (preferring to pay once instead of every single ticket) and ecological reasons. Reasons for low acceptance are the obligation to pay for the ticket and the unbalanced extension of the validity area exclusively

to NRW. Since Bielefeld is located close to the border of NRW, many students come from the neighbouring state Lower Saxony and, thus, do not profit from the extension of their semester ticket, because there are no options to extend the semester ticket outside of NRW.

The students were also asked whether they would like to keep the extension of their semester ticket from regional to state level if they could choose or not. As a result, three quarters of the students support the extension of their semester ticket to state level and would prefer to keep the extension, one fifth prefers to abolish the extension (figure 5). The students disapproving the extension on state level were further asked if they would also prefer to abolish their regional semester ticket. As a result, most of those students would vote for the continuation of their regional semester ticket. Thus, in total only 2% of the students disapproved both regional and state-wide valid Semesterticket – a result which demonstrates the high acceptance of semester tickets at the University of Bielefeld in general.

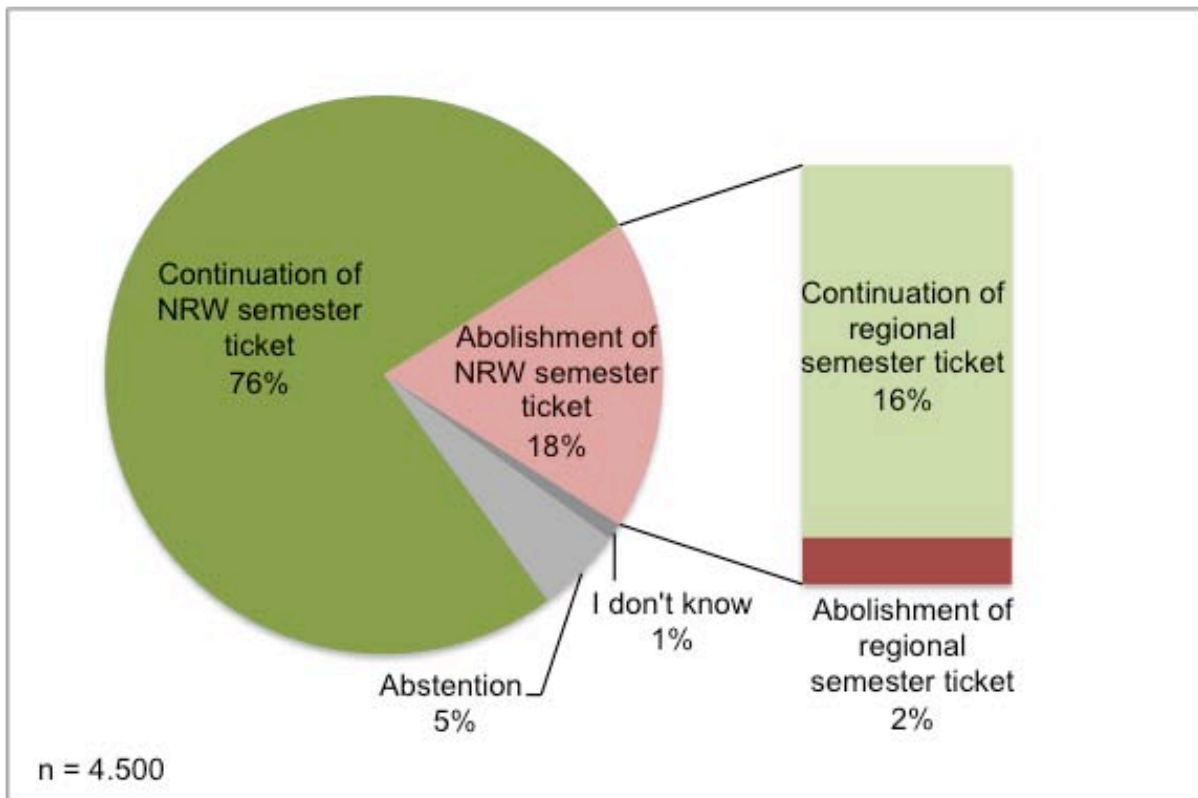

Figure 5: Acceptance of the extension of the semester ticket from regional to state level by the NRW semester ticket at the University of Bielefeld (2010)

Effects of the NRW semester ticket on students' mobility behaviour

To assess the effects of the NRW semester ticket, students were asked ex-post how they would have performed trips which they travelled with the NRW semester ticket in the week before participating in the online survey if they had not possessed the NRW semester ticket.

As a result, 44% of the trips would have been travelled with the same means of public transport. 28% of the trips would not have been travelled at all. Thus, the new mobility options induced new trips and enabled students to be more mobile. 22% of the trips were shifted from other modes of transport: 18% of the trips were shifted from car to public transport and 3% were shifted from walking and cycling to public transport. The low amount of trips shifted from walking and cycling is due to the fact that mainly long distance trips are travelled with the NRW semester ticket. In the immediate surroundings of a university, the mode shift from walking and cycling to public transport is higher (see section 4.1).

Effects of semester tickets on car ownership

Besides the effects of the NRW semester ticket on mobility behaviour, students were asked which effects semester tickets have on car ownership. As a result, more than one third of the students stated that semester tickets had an effect on their car ownership. Students at the University of Bielefeld can be divided into three groups 'car owners' (28% of the students), 'former car owners' (15%) and 'car-free students' (57%). In the online survey, 17% of the car owners stated that semester tickets make them think about abolishing their car. 37% of the former car owners stated, that semester tickets were one reason why they abolished their car. And 44% of the car-free students stated that semester tickets were one reason for their decision not to purchase a car (figure 6)

Also official student statistics give some indications on the effects semester tickets can have on car ownership among German university students: Whereas in 1991 53% of the German students had expenditures for a car, the share has declined to 34% since 2009 (figure 7). The introduction of semester tickets is pointed out as

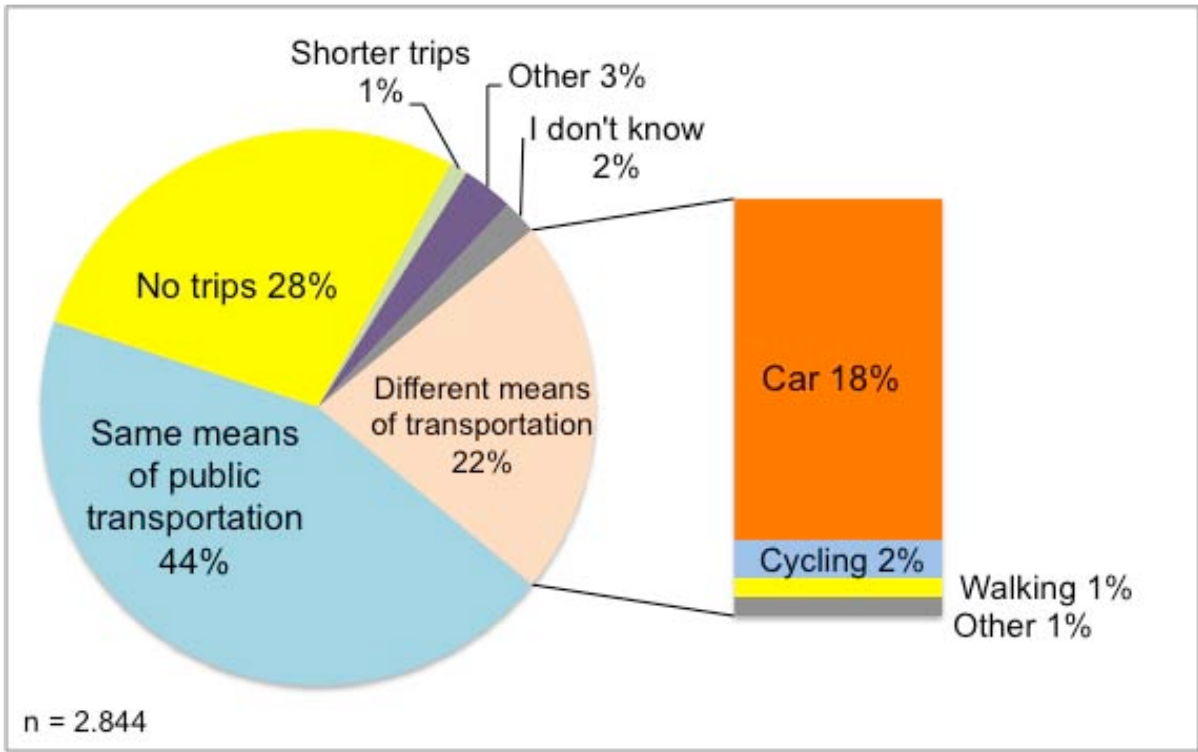

Figure 6: Effects of the NRW semester ticket* on student mobility behaviour
 'How would you have travelled this trip/these trips if you would not have had a NRW semester ticket?'

*Please note: Only trips within the extension of the semester ticket from regional to state level were evaluated, not trips travelled within the regional validity of the semester ticket. The question refers to trips which the students have travelled on specific days in the week before participating in the online survey. Source: Müller 2011

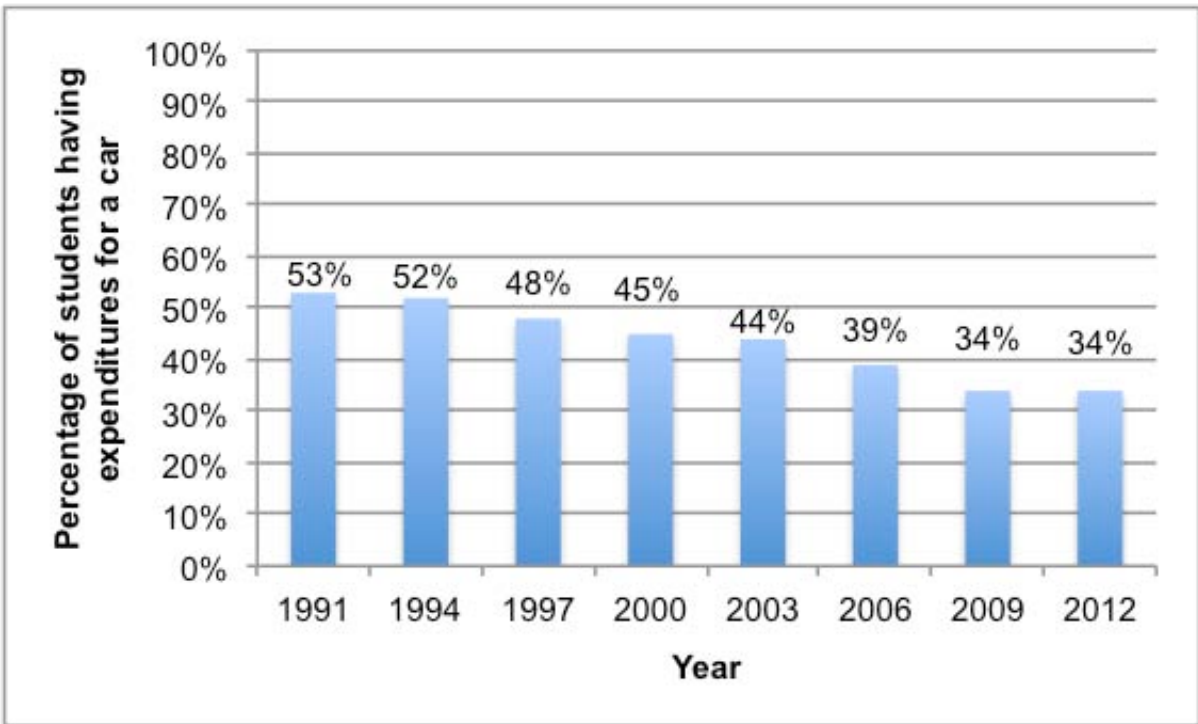

Figure 7: Proportion of students having expenditures for a car in Germany (1991 to 2012)

one reason for the decreasing number of students who have expenditures for a car (Schnitzer et al. 1998: 552f).

5. Conclusions

Today, almost all universities in Germany have introduced semester tickets for their students to use public transport and student acceptance is very high. Semester tickets are financed in solidarity by the students: All students of a university have to pay an obligatory solidary contribution and automatically receive a public transport ticket for 6 months.

Over the course of time, the geographical reach of some semester tickets was extended remarkably – up to state level. Semester tickets make a valuable contribution to sustainable student mobility, because they foster mode shifts from car to public transport and have an effect on the reduction of car ownership. Semester tickets broaden the mobility options of students, who can be mobile independently from car ownership and financial resources. Furthermore, semester tickets have a positive effect on the mobility socialisation of young people towards a sustainable mobility culture.

Unwanted effects of semester tickets are mode shifts from walking and cycling to public transport, which underline the need to develop holistic mobility concepts at universities and to implement mobility management measures promoting all kinds of sustainable mobility options for students, for example by including bike sharing systems into semester tickets or establishing mobility funds for promoting a wider range of sustainable mobility options (see for example University of Leipzig in table 1).

Citizen tickets – Introducing a ‘semester ticket for everybody’?

In Germany, there are currently intensive discussions on the future financing options of the German public transport system due to eroding financing bases: public financing is decreasing because of precarious budget situations and debt ceilings, revenues from the energy sector which are used to cross-finance public transport are diminishing and there are significant de-

mand drops in some regions due to demographic changes. At the same time, there is a high infrastructural backlog demand for the transport system and additional investments are needed due to social, environmental and climate protection reasons. Hence, new financing instruments are currently discussed in Germany, like the imposition of levies, contributions and taxes for potential users and third-party beneficiaries of public transport services (employers, trade, real estate and property owners, motorists and the general public). In this context, the introduction of a citizen ticket (‘Bürgerticket’) at community level, a ‘semester ticket for everybody’, is discussed both scientifically and politically (Maaß et al. 2015; Zimmer 2015; Bracher et al. 2014; Maaß & Waluga 2014). Citizens would be obliged to pay a regular contribution for public transport and could, in return, get access to public transport to a certain extent. Whereas free public transport had been implemented in two small German cities in the past (Templin, Lübben), a citizen ticket has not yet been implemented in Germany or elsewhere.

Since semester tickets have been implemented at almost all universities in Germany, they are well accepted and highly appreciated by the students and make a valuable contribution to sustainable mobility, the options to introduce a citizen ticket should be further analysed. Similar ticket concepts exist already today (guest tickets, event tickets, semester tickets). Citizen tickets might offer a solution for constrained public finances and open up new possibilities for designing a high quality, affordable, sustainable and climate-friendly transport system. The author proposes to test and analyse the options to introduce a citizen ticket in the realistic settings of a pilot project at municipal level.

Author details:

Dipl.-Geogr. Miriam Müller, M.A.
Research Group 2: Energy, Transport and Climate Policy
Wuppertal Institute for Climate, Environment and Energy
Döppersberg 19
42103 Wuppertal
Germany

Email: miriam.mueller@wupperinst.org

References:

Blees, V., Boltze, M., Stanek, G. (2001): Wirkungen des Semestertickets. Analyse am Beispiel des Hochschulstandorts Darmstadt. In: Der Nahverkehr 3/2001, pp. 30-35.

Blickfeld – die CampusZeitung für Wuppertal (2014): VRR-Semesterticket soll bis 2019 um 43% teurer werden. Wuppertal. <http://www.blickfeld-wuppertal.de/on-campus/vrr-semesterticket-soll-bis-2019-um-43-teurer-werden>.

BMBF – Bundesministerium für Bildung und Forschung (2013): Die wirtschaftliche und soziale Lage der Studierenden in der Bundesrepublik Deutschland 2012. Berlin. http://www.sozialerhebung.de/download/20/soz20_hauptbericht_gesamt.pdf.

Hunecke, M. (2015): Mobilitätsverhalten verstehen und verändern. Psychologische Beiträge zur interdisziplinären Mobilitätsforschung. In: Gather, M., Kagermeier, A., Kesselring, S., Lanzendorf, M., Lenz, B., Wilde, M. (editor): Studien zur Mobilitäts- und Verkehrsforschung. Wiesbaden.

Kling, T., Esser, K., Schmidt-Freitag, W., Holzhausen, U. (1996): Akzeptanz und Nutzung des SemesterTickets an der Uni Köln. Untersuchung zum Mobilitätsverhalten von Studenten. In: Der Nahverkehr 5/96, pp. 62-70.

Maaß, Ch.; Waluga, G. (2014): Neue ÖPNV-Finanzierungsinstrumente für Länder und Kommunen. In: Verkehr und Technik 2014, issue no. 10, pp. 397-401.

Maaß, Ch., Waluga, G., Weyland, R. (2015): Fahrscheinlos – Grundlagen- und Machbarkeitsstudie Fahrscheinloser ÖPNV in Berlin. Hamburg Institut Research. Published by Piratenfraktion im Abgeordnetenhaus von Berlin. Berlin. http://opus.kobv.de/zlb/volltexte/2015/26023/pdf/Piratenfraktion_Studie_Fahrscheinloser_OEPNV_Berlin_Juni_2015.pdf.

Müller, M. (2011): Das NRW-Semesterticket. Akzeptanz, Nutzung und Wirkungen dargestellt am Fallbeispiel der Universität Bielefeld. In: Wuppertal Institut für Klima, Umwelt, Energie (editor): Wuppertaler Studienarbeiten zur nachhaltigen Entwicklung, Nr. 1, September 2011. Wuppertal. <http://epub.wupperinst.org/frontdoor/index/index/docId/3936>.

Ochse, S, Richter, S. (2012): Integration von Energiedienstleistungen in die Modellierung kommunaler Energiesysteme. In: Knoll, Michael; Oertel, Britta (editor): Dienstleistungen für die energieeffiziente Stadt. Berlin/Heidelberg, pp. 95-108.

Preistrup, M., Stingel, S. (2007): Preisbildung bei Semestertickets bezieht alle Studenten mit ein. In: Internationales Verkehrswesen, volume 59, 9/2007, pp. 386-391.

Reutter, U., Müller, M. (2015): Solidarfinanzierung im ÖPNV durch Semestertickets. Effekte auf das Verkehrsmittelwahlverhalten Studierender und Übertragbarkeit auf andere Nutzergruppen. Presentation at the Enquête Commission IV „Financing Options for Public Transport in North Rhine-Westphalia in the context of societal and technical change“ (FINÖPV) at the Landtag of North Rhine Westphalia on May 8th, 2015. https://www.landtag.nrw.de/portal/WWW/GB_1/I.1/EK/16.WP/EK_IV/TOP_2_UlrikeReutter_EKIV_Solidarfinanzierung_im_OePNV_durch_Semestertickets_150508_web.pdf.

Schnitzer, K., Isserstedt, W., Müßig-Trapp, P., Schreiber, J. (1998): Das soziale Bild der Studentenschaft in der Bundesrepublik Deutschland. 15. Sozialerhebung des Deutschen Studentenwerks durchgeführt durch HIS Hochschul-Informationssystem. Published by Bundesministerium für Bildung und Forschung, Bonn. http://www.sozialerhebung.de/archiv/download/15/Soz15_Ges.pdf.

Schreiber, J. (1996): Studentische Verkehrsmittelwahl in den Hochschulstädten. Ergebnisse der 14. Sozialerhebung des Deutschen Studentenwerks. HIS Kurzinformation, July 1996, Hannover.

VRR – Verkehrsverbund Rhein-Ruhr (2013): Weiterentwicklung SemesterTicket. Unpublished presentation from June 19th, 2013.

Zimmer, Ch. (2015): ÖPNV-Finanzierung – Grundlagen und Lösungsansätze für einen ÖV-Beitrag. Presentation at the Enquête Commission IV „Financing Options for Public Transport in North Rhine-Westphalia in the context of societal and technical change“ (FINÖPV) at the Landtag of North Rhine Westphalia on May 5th, 2015. https://www.landtag.nrw.de/portal/WWW/GB_I/I.1/EK/16.WP/EK_IV/TOP_3_ChristophZimmer_EKIV_Finanzierung_OePNV-Beitraege_150508_ergaenzt.pdf.

Leveraging collective action for a seat-belt wearing intervention in Afyonkarahisar, Turkey

Huseyin Akbulut, Serap Sener, Fatih Vuravas and Meleckidzedek Khayesi

Introduction

Policy change through action on existing opportunities, knowledge and practices to address problems facing humanity is a longstanding topic in public policy research (Glasgow, Lichtenstein and Marcus, 2003; Plowman et al., 2007; Banister, 2008). In the case of road safety policy, a major concern is that though knowledge and measures to improve the road safety situation in low- and middle-income countries exist, their translation into practical solutions on the ground has been low (Peden et al., 2004; Bugeja et al., 2011). There are several reasons offered for this low uptake, including low priority given to the issue by political leaders, financial constraints, lack of evaluation research, limited human resources, competing development and health priorities, and limited policy integration (Peden et al., 2004; Bliss and Breen, 2009; Hyder, 2013; Canoquena, 2013). This low uptake surprises some researchers and practitioners who look at road safety measures as simple and low-cost, virtually low-hanging fruit, consisting of efforts such as reducing vehicle speed, wearing a helmet, controlling alcohol impairment and wearing a seat-belt (Insurance Institute for Highway Safety, 2011). One can theoretically expect low- and middle-income countries to leapfrog the painful road safety learning curve of high-income countries, given the knowledge and experience available. While the analogies of low-hanging fruit and leapfrogging sound viable and attractive, it is important to remember that policy change, which includes knowledge translation, is a complex political, methodological and conceptual issue, requiring decisions and actions by different state and non-state players, politicians, administrators, civil society representatives, users and the general public (Capano, 2009; Capano and Howlett, 2009; Lane, 1983; Zohlnhöfer, 2009). For example, in her action situation model, Ostrom (2010) argues that different actors who occupy different positions play a key role in making decisions and taking

actions that will lead to certain outcomes in a policy action situation.

Road safety policy research generally lacks a rich collection of lived experiences and case studies of translating knowledge and practices into solutions on the ground in local settings. Most road safety studies, a number of which are now summarized in literature reviews (see for instance Elvik et al., 2009), are based on the quantitative scientific approach, leaving out the intricate description of how the existing knowledge is actually negotiated and implemented (Bugeja et al., 2011). We argue that the aspiration of leapfrogging and picking the low-hanging fruit in road safety policy may not easily occur given contextual factors and gatekeepers who influence the development and implementation of road safety solutions. These factors and gatekeepers — those people with power and responsibility to control things in society — constitute leverage points in a system at which intervention may be conducted to secure decisions and mobilize actions toward implementing measures. As explained by Meadows (1999: 1), leverage points are places within a complex system (a corporation, an economy, a living body, a city, an ecosystem) where a small shift in one thing can produce big changes in everything. It is therefore important for road safety research to examine not only the magnitude of road traffic injuries and predict the contribution of related risk factors but also the implementation context, including leveraging and negotiating multiple agencies and gatekeepers to translate scientific knowledge and practices into solutions in different settings. Using Elinor Ostrom's (2010) concept of action situation as an analytical framework, this paper examines how actors occupying different positions interacted and negotiated several issues to implement a road safety programme in Afyonkarahisar in Turkey.

A policy action situation

Road safety research points out the importance of multisectoral coordination, political will, capacity and focused action in implementing road safety solutions (Peden et al., 2004; Hyder et al., 2012; Hyder, 2013) but it does not fully elaborate on how actors from different centres of power

and decision-making structures affect the process and outcomes of implementing measures in a local setting. This gap in road safety research should not be interpreted to mean that road safety researchers and practitioners are not aware of these political and contextual issues. They are quite aware, as highlighted in research papers (see for instance, Bergman et al., 2002; Frattaroli et al. 2006; Bugeja et al., 2011; Treviño-Siller et al., 2011; Hyder, 2013; Lyons et al., 2013). What seems to be lacking is the elaboration or adoption of existing theoretical frameworks and conceptual models to analyse these issues. An example of an exception to this conceptual gap in road safety research is a recent study that has proposed characteristics of an effective response to the implementation gap in global road safety, based on health literature that described these elements individually (see Figure 1). This effort is commendable as it is likely to lead to refinement of these concepts and variables as researchers and practitioners test them in empirical research or share their experiences from implementation of road safety interventions. This effort may help to shift some aspects of road safety research that tend to be largely focused on

quantitative assessment of the risk factors and outcomes of interventions (see for instance Elvik et al. 2009), paying limited attention to the role of contextual factors of politics, power, institutions, trust, cooperation and interactions in the implementation of interventions. Another exception is the work of Belin (2012) who has applied a number of public policy theories and models to analysis of road safety policy of Sweden, commonly referred to as Vision Zero.

The stage policy model — consisting of defining the problem, analysing causation, considering and selecting effective solutions, and implementing and evaluating solutions —seems to dominate research approach to road safety policy analysis (Bugeja et al. 2011). While this model has value in risk factor analysis and developing effective interventions, researchers who apply it in programme implementation have not fully articulated the complexity of policy implementation that involves decisions and actions by different players (Rittel and Webber, 1973; Levin et al. 2012). While acknowledging the commendable conceptual effort shown in Figure 1, we looked outside the existing road



Figure 1: Proposed characteristics of effective response to implementation gap in global road safety
 Source: Hyder et al. (2012: 1063)

safety literature to explore frameworks in policy science studies that could provide concepts and approaches to help us analyse negotiations in a local road safety policy action situation, involving decisions and actions by different actors. We found the research conducted at the Workshop in Political Theory and Policy Analysis at Indiana University, especially the institutional analysis and development (IAD) framework, appropriate in offering concepts and variables to examine interaction and outcomes in a specific seat-belt wearing policy situation action in Afyonkarahisar in Turkey .

An action situation, a core concept in IAD framework (see Figure 2), refers to a process or issue of interest “in which individuals (acting on their own or as agents of organizations) observe information, select actions, engage in patterns of interaction, and realize outcomes from their interaction” (McGinnis, 2011: 169). The action situation is affected by external variables such as biophysical conditions, attributes of the community and rules-in-use, generated patterns of interactions and outcomes that are evaluated by participants in the action situation, and feedback on both the external variables and the action situation

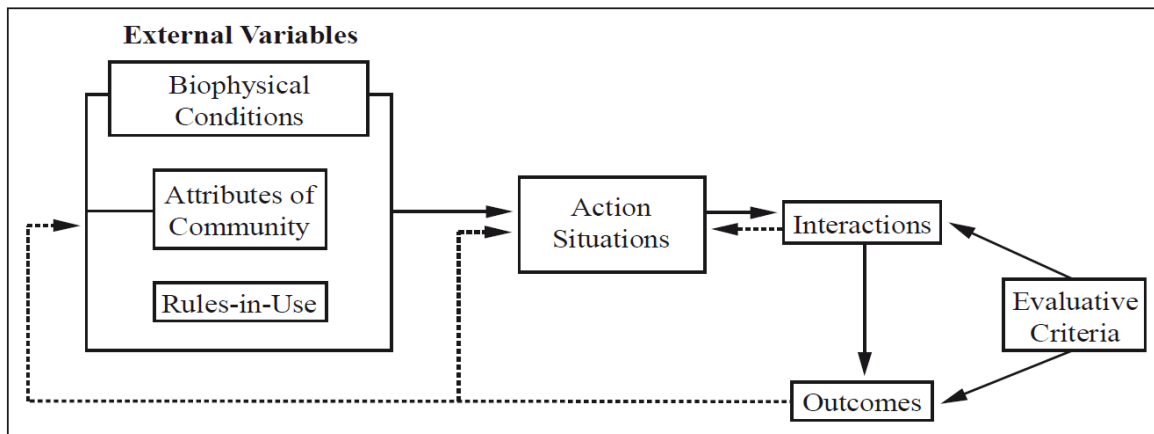

Figure 2: A framework for institutional analysis

Source: Ostrom (2010: 6)

itself (Ostrom, 2010).

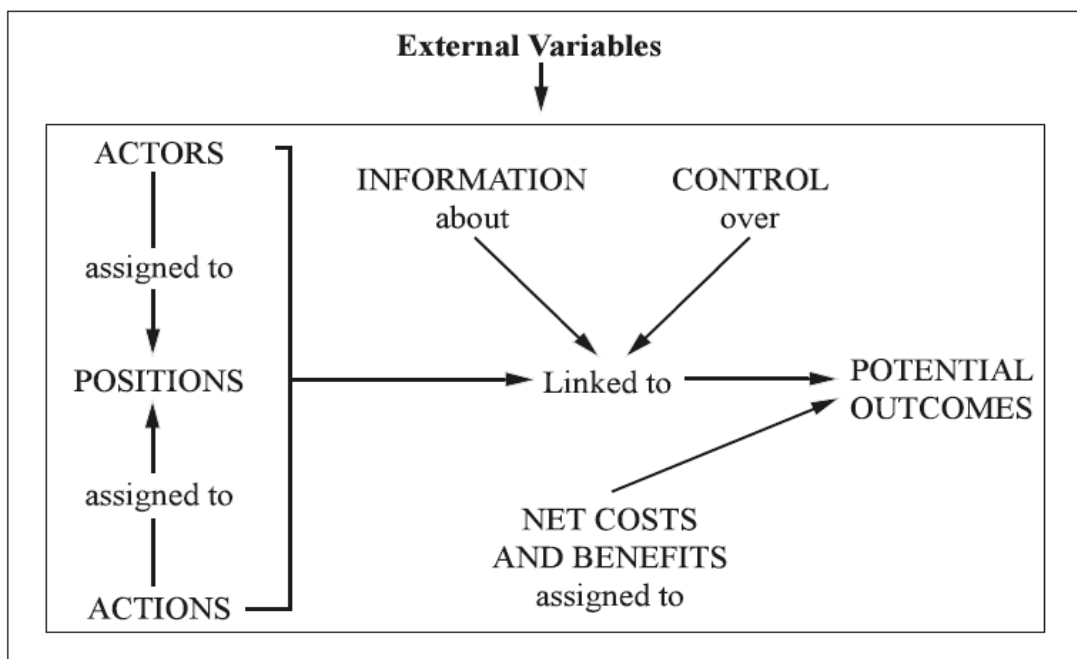

Figure 3: The internal structure of an action situation

Source: Ostrom (2010:8)

An action situation is made of participants or actors in positions who must decide among diverse actions. They must do this in light of the information they possess about how actions are linked to potential outcomes, the costs and benefits assigned to actions, and outcomes (McGinnis, 2011; see Figure 3).

Findings from extensive investigations, spanning about 50 years, conducted by Ostrom and colleagues in micro level settings around the world have challenged the commonly held view about chaos and disorder in institutional arrangements meant to manage common resources and provide public services. Instead of chaos, these findings reveal that resource users and public service providers devise an immense number of different rules and procedures fitting their local resource systems and action situations. The findings show that individuals are not necessarily trapped in a helpless situation of not being able to address or find solutions to local issues but rather they develop rules and institutions to guide their actions. These findings on experiences of communities led Ostrom and colleagues to advance the concept of polycentricity within IAD (Ostrom, 2010). Polycentricity refers to “a system of governance in which authorities from overlapping jurisdictions interact to determine the conditions under which these authorities, as well as the citizens subject to these jurisdictional units, are authorized to act as well as the constraints put upon their activities for public purposes” (McGinnis, 2011: 171). Viewed from a polycentricity perspective, a policy situation action may consist of actors or players from local, provincial, national, regional and global levels, brought together to interact and contribute to decisions and actions on an issue. The actors and authorities involved may have specialized or general purposes and functions, straddling public, private, voluntary and community-based sectors.

The overlapping jurisdictions and actors mentioned above represent leverage points, which are essentially centres of power in a system (Meadows, 1999). The implication of this reality is that improving road safety is not only about specifying technical measures but also about inter-

vening in a system of institutions, procedures, relationships, regulations, politics, economics and power. Whereas evidence-based road safety policy puts emphasis on changes in behaviour and the number of fatalities resulting from implementing measures such as reduction of vehicle speed and control of alcohol-impaired driving, it is important to consider evidence about how systems work and ways of bringing about a change in a human system. There are several policy models on how systems change comes about but in the case of leveraging change, the key consideration is identifying the leverage points and intervening appropriately. As Meadows (1999) has pointed out, the level at which one intervenes in a system may determine the effectiveness of the intervention. At the basic lowest level, one can intervene in ways and at points that do not significantly change how things are done. At the highest level, one can intervene by changing the paradigm from which the system arises or with those who possess the power to transcend an existing paradigm.

Methods

Empirical setting

Afyonkarahisar, Turkey, is one of the road safety policy action situations or sites in a programme implemented in ten low- and middle-income countries (viz. Brazil, Cambodia, China, Egypt, India, Kenya, Mexico, Russia, Turkey and Viet Nam) over a 5-year period from 2010 to 2014 (Peden et al., 2012). The goal of the project, then known as the Bloomberg Philanthropies Global Road Safety Program (BPGRSP), was to save lives through the implementation of good road safety practices. In each local site, the focus was on two risk factors, with the intention of addressing more risk factors in more places in the long-term. The programme involved six Consortium Partners (Global Road Safety Partnership, WHO, Johns Hopkins Bloomberg School of Public Health International Injury Research Unit, Association for Safe International Road Travel, World Bank and EMBARQ World Resources Institute) as well as several national and local partners. The Consortium partners were expected to provide technical and financial support to



Figure 4: Location of Afyonkarahisar

national and local governments and other agencies to implement good practices in road safety in line with their national road safety strategies. We shall give details on this project in a later section; however, it is relevant to policy analysis that BPGRSP cuts across many institutions, disciplines, national political settings, economic development levels, national capacities and individual players.

The city of Afyonkarahisar, located in Western Turkey, has a population of about 400,000 people. It is surrounded by several rural settlements. Afyonkarahisar city is a major intersection or node in the road transport system in Turkey and Europe (Figure 4). It has heavy and high-speed vehicle traffic passing through it due to tourists visiting the Mediterranean Sea coast and Aegean Region from the major cities such as Ankara and İstanbul in Turkey and several cities from other European countries. Road traffic crashes are a problem in Afyonkarahisar (see Figure 5).

More than 4,000 people lose their lives in Turkey every year as a result of road traffic crashes (WHO, 2013). This figure represents those who are killed at the scene of road traffic crashes. It is estimated that another 5000 people die on their way to the hospital or in the hospital in Turkey. The majority of those killed on Turkish roads are drivers and passengers of four-wheeled vehicles, although pedestrians, cyclists and motorcyclists account for nearly one-quarter of the deaths. Research points out the need to improve road safety in Turkey (see for instance, Tansel, 1989; Esiyok, 2005).

Research variables

The concepts that we found relevant to this study from the action situation concept were actors, positions, actions, interactions, context and outcomes. The outcomes of BPGRSP were grouped into three sets of indicators. The first group consists of main indicators, including deaths, injuries and number of crashes. The second

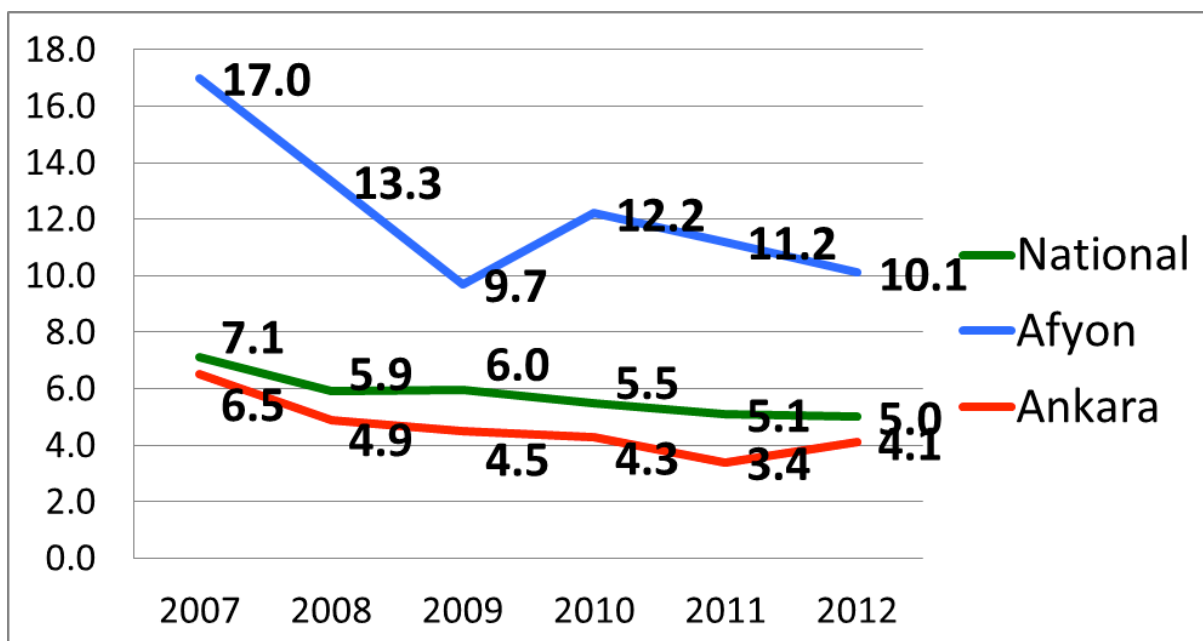

Figure 5: Road traffic death per 100 000 population, Afyonkarahisar and Ankara, 2007-2012

Source: Johns Hopkins International Injury Research Unit

group is made of intermediate indicators, consisting of behaviour change such as seat-belt wearing and driving speed in the case of Afyonkarahisar. The third group is made of process indicators, including preparing work plans, setting up national and local project working groups, planning and holding project meetings, reviewing and improving legislation on particular risk factors, conducting social marketing campaigns, conducting training, purchasing and delivering equipment, training police officers and enforcing traffic laws. These outcomes required interaction and actions by different actors as indicated in Figure 3.

Data collection

The information used for this study, as is common with case studies, was gathered from multiple sources: project documents, project studies, authors' project notes, and documents from local and national agencies in Turkey. The information gathered from these sources is briefly summarized below.

Project documents

BPGRSP generated several documents with useful information. In Turkey, the main documents we utilized were minutes or records of planning meetings, progress reports and project briefings. There were

regular planning meetings in each site and national project committee. Minutes of these meetings provided details on the nature of discussions and decisions made. There were also monthly, quarterly and annual progress reports that provided details on achievements and challenges faced. Further, there were regular project briefings on specific and general issues. These briefings were prepared for different partners such as the donor, global project coordinator, government ministers, members of parliament and the media.

In addition to the reports mentioned above, this project relied on conducting a number of assessments and studies to gain insight into relevant contextual and project issues as well as to examine progress. These studies were designed and conducted using appropriate methods such as surveys, review of documents, focus groups and roadside observations. The main studies that were conducted in Turkey were:

- a stakeholder mapping that was conducted at the beginning of the project to identify main players in road safety, their priorities, interests, influence and potential role. This information was helpful in selecting project partners at local and national levels;
- identification of relevant laws and regulations that address road safety,

an assessment against best practices of these law and regulations to identify gaps, and translation of evidence-based practice into recommendations for improvement of these laws and regulations (Öztürk, 2011);

- assessment of changes in the public knowledge, attitude, behaviour and perception of risk factors, and legislation and enforcement of traffic law with regard to seat-belt wearing and speed control. While some of the data collected on these variables have already been published (e.g. Milder et al., 2013), other data on pre- and post-survey on knowledge, attitudes and perceptions of seat-belt wearing for social marketing campaigns have not; and
- analysis of routinely collected data on road traffic injuries.

Johns Hopkins International Injury Research Unit evaluated changes in behaviour, injuries and fatalities in all the ten countries participating in the BPGRSP. An important outcome of this effort was to provide information for planning activities. Results of the evaluation were also published in journals. This effort built the evidence base on the evaluation of interventions in low- and middle-income countries, which has been limited. For Turkey, two papers have been published on the burden of road traffic injuries (Puvanachandra et al., 2012) and seat-belt wearing (Milder et al., 2013). In addition to published papers, the Johns Hopkins International Injury Research Unit provided a summary of the findings to project partners.

Authors' project notes

The authors were members of the project planning and coordinating teams. They took notes during meetings and consultations. The notes had details on project deliverables, decisions, actors, decisions and several planning issues related to activities of the project.

Analysis

We extracted information from all the sources indicated above to generate details on the main variables of interest for this study: actors, positions, actions, interactions, context and outcomes. We

conducted an interpretive analysis based on the information gathered and our experience of supporting the implementation of this project in Afyonkarahisar.

How did Afyonkarahisar come to be included in the over 20 policy action situation sites of BPGRSP?

Ostrom (2010) argues that the local action situation is influenced not only by actors and structures in the local setting but also by the broader or external political, economic and social contexts. The origin of the BPGRSP shows how decision-making and actions in different international organizations lead to initiatives that are implemented at the local level. Though a global mechanism had been established in 2004 through the United Nations Road Safety Collaboration to advocate for road safety measures worldwide, financial resources continued to remain a constraint. In 2007, Bloomberg Philanthropies provided WHO with funding to support implementation of road safety measures in Mexico and Vietnam. A third country, Cambodia, was added, following savings from funds meant for collection of data for the first global status report in the Western Pacific Regional Office. In 2010, Bloomberg Philanthropies increased the financial support to US \$125 million and brought in five other international agencies to provide technical support to implement proven and effective interventions in ten low- and middle-income countries for five years, 2010-2014 (Bloomberg Philanthropies, 2012). Turkey was one of the ten countries chosen.

A few questions may arise: a) Why did Bloomberg Philanthropies become interested in road safety?; and b) Why were these ten countries selected? Bloomberg Philanthropies has indicated that it was looking for health problems that have a high burden of disease for which there are proven interventions but were not supported by donors. A thorough assessment identified road traffic injuries to be such a problem. The ten countries were selected on the basis of the burden of death due to road traffic injuries, political commitment to road safety and existing capacity to address the problem. It was estimated that as of 2010, these ten countries make up almost half of road traffic fatalities glo-

bally (Bloomberg Philanthropies, 2012). Though several donors had provided financial support to global road safety efforts, Bloomberg Philanthropies funding of US \$125 million has been indicated as the highest sum in absolute terms received for a single project. This high level of funding may explain why this financial support and programme has been referred to as a global opportunity (Hyder and Bishai, 2012).

One of the initial steps taken in developing the project in Turkey, as was the case in the other nine countries, included making decisions about project implementation sites, risk factors and a work plan. The Consortium partners working on road safety in Turkey were the WHO, Global Road Safety Partnership, Association for Safe International Road Travel and the Johns Hopkins International Injury Research Unit. In addition, World Resource Institute's Centre for Sustainable Transport worked on sustainable transport in other locations in Turkey. The Consortium partners hired and/or designated staff to work on the project in Turkey. WHO office in Turkey, playing the role of project coordinator, liaised with the relevant government agencies and identified representatives from different institutions who could contribute to planning and implementing the project. A first project planning meeting was held on 3-4 June 2010 in Ankara. Potential project sites, risk factors, and scope were suggested. After an intense discussion, the main outcomes of the meeting were as follows: speed and

seat-belt were agreed upon as the risk factors (see Box 1), Afyonkarahisar and Ankara were identified as project sites (it was agreed that a third one, Kocaeli, would be added if there were adequate financial resources), names of people and institutions were proposed for membership of project steering committee, and dates for the second planning meeting were proposed.

It is necessary to note that it was not simply a matter of reaching consensus on the above issues. There were animated discussions as to why the focus was only on two risk factors, why infrastructural measures were not central in the project and which sites to select. While Ankara was thought to be inappropriate for such a short-term project, some participants argued that it was too important a site of political power to be left out of the project. Most of the remainder of 2010 was used to set up project coordinating committees at the national and local levels, conduct situational assessments, hold a second planning meeting on the 30th of September 2010, and begin to plan activities in the two project sites. A national project coordinating committee was formed. In Turkey, this project is implemented by the Ministry of Interior (Turkish National Police and General Command of Gendarmerie) and Ministry of Health, in collaboration with the Ministry of Transport, Maritime Affairs and Communication.

Box 1: Consenting and dissenting evidence on road safety measures

The risk factors addressed in the ten countries were speeding, alcohol-impaired driving, non-use of helmets, and non-use of seat-belts and child restraints. It is important to note that there is no complete consensus in the scientific literature on effectiveness of measures developed for these risk factors. Whereas the commonly cited evidence shows that wearing seat-belts reduces the risk of a fatal injury by up to 50% for front seat occupants and up to 25% for rear seat occupants (Peden et al., 2004; Elvik, et al. 2009; WHO, 2013), other researchers have analysed the evidence and concluded that seat-belt regulation and traffic regulation in general can contribute to a phenomenon known as risk compensation, leading to adjustment in driving behaviour due to perception of risk (Peltzman, 1975; Wilde, 1982; Adams, 1995). In the case of speeding, whereas earlier work by Pasanen (1991) showed that a pedestrian had a 90% chance of surviving car crashes at speeds of 30 km/h or lower but less than a 50% chance of impacts at 45 km/h, recent research that has adjusted for sampling and statistical analysis bias in earlier studies has derived results showing that an adult pedestrian has approximately a 20% risk of dying if struck by a car at 60km/h (Rosén, Stigson and Sander, 2011). The scientific and practice community is still engaged in discussion on the consenting and dissenting voices on effectiveness of road safety policy measures related these risk factors.

The rubber meets the road: situating the interventions in the local political and institutional context of Afyonkarahisar

Identifying or creating an opportunity is one thing, and utilizing it adequately and addressing effectively the challenges along the way is another. How did this global opportunity play out in Turkey? A major effort by all countries that participated in the five-year road safety project was to try and move quickly beyond project set-up and begin to implement specific activities. For Turkey, it took a little longer to get WHO staff hired. In 2010-2011, a social marketing campaign, "Life has the right of way over time," and enforcement operations on seat-belt wearing were conducted in both Afyonkarahisar and Ankara. Results of an observational study conducted by the Johns Hopkins International Injury Research Unit showed that there was a negligible change in the seat-belt wearing rate. In Afyonkarahisar, the seat-belt wearing rate increased from 3.9% in November 2010 to 6.8% in November 2011 (see Figure 6).

In a review meeting held in November 2011 in Ankara, the partners decided to focus on Afyonkarahisar and on a single risk factor, the non-use of seat-belts, to consolidate their efforts and provide a firm

basis for adding another risk factor and site. There was substantial discussion in days that followed the review meeting as to what or who was at fault for the poor results. While enforcement was identified as having been poorly executed, some felt the problem was due to inadequate traffic police officers in the two project sites, lack of cooperation from the local police chief and corruption among traffic police officers. There were others, especially from the local level, who argued that they had not received adequate external support to prepare and execute a viable enforcement plan. Another view that emerged was that the project had not been prioritized and fully supported by the local political leaders and managers in key institutions. As the reflection continued, reference was made to the success of Turkey in a tobacco control intervention and the road safety project group was urged to emulate this example.

The excitement about Turkey being part of the global road safety policy change opportunity was greeted by project partners with deep reflection and uncertainty about the viability of achieving results at the beginning of 2012. In January-February 2012, the project coordinator based in the WHO office in Turkey conducted several visits and held discussions with key political

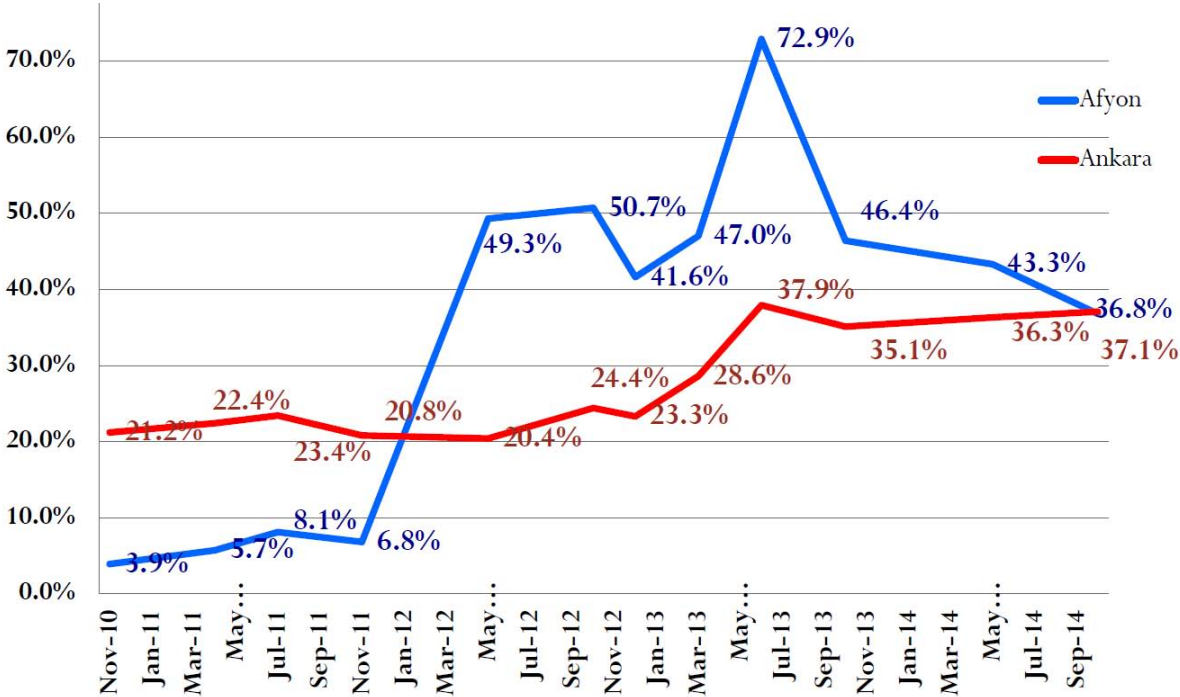

Figure 6: Proportion of all occupants wearing seat-belts in Afyonkarahisar and Ankara, Turkey, 2010-2014

Source: Johns Hopkins International Injury Research Unit (2014)

leaders and managers in Afyonkarahisar to re-introduce the project and urge them to provide full support to its implementation. Elections had just been held in Afyonkarahisar and Turkey. The project coordinator visited the new governor of Afyonkarahisar, who was receptive to the project as he had prioritized road safety as one of his flagship and legacy projects. Through this consultative process, we learnt that there was an existing and ongoing effort to address road safety issues in Afyonkarahisar and there was even a framework of coordination that had been developed. The new governor pointed the project coordinator to an academic at a local university. This academic proved resourceful and key as he was trusted and had access to a number of key political leaders and institutional managers in Afyonkarahisar. The project was then re-conceptualized as a local Afyonkarahisar initiative, building on an existing initiative and coordinated by local institutions, with the Consortium partners and national level agencies coming in only to provide technical support. We summarize below the ways in which decisions and actions by different centres of power were undertaken to address the

road safety situation by initially focusing on seat-belt wearing.

Creating a coordinating mechanism

A coordination group was formed in Afyonkarahisar, consisting of a deputy governor, traffic section director of the city police department, chief of traffic from the Provincial Command of Gendarmerie and a professor from Kocatepe University (see Figure 7). The group adopted a devolved, interactive governance approach in which issues were discussed and plans drawn up among equals committed to addressing the problem of road safety. Recourse to hierarchy was kept to the minimum in the coordination group. The group made an effort to take into account the political and social context of Afyonkarahisar when planning the project. In this regard, the group took two steps.

First, the goal and objectives of the road safety project were explained to the highest local administrator of the city, the Governor of Afyonkarahisar, and his full support was obtained. Further support was then obtained from the Afyonkarahisar



Figure 7: Afyonkarahisar road safety project coordinating group

Police Department, Mayor and Rector of Kocatepe University. The logic behind this step was that for the road safety project to succeed, the contributions of all key institutions and organizations in the city were necessary. Duties and responsibilities of all institutions were clearly identified. Second, the coordinating group adopted the principle of equality of all citizens before the law, pointing out that no one would be exempt from obeying the traffic law. Emphasizing this principle was found necessary in view of the concern that some members of society might not be subject to traffic rules because of their socio-economic status. Thus, both the enforcement of the traffic law and dissemination of information had to take into account all members of society. Everyone would be subject to the penalties uniformly.

The coordinating group decided to focus on education and enforcement (or the '2Es' of the Afyonkarahisar coordinating group) instead of education, enforcement, engineering, environment and emergency services (5Es), the comprehensive approach suggested in literature. This decision was based on limited time and resources available for the project. Education focused on three aspects: disseminating information and raising awareness among the public; educating public institutions and organizations; and creating a welcoming environment. Enforcement was approached in two ways: on-site enforcement and electronic surveillance.

Local political leadership and gatekeepers make decisive moves

One of the reasons that enforcement was thought to be ineffective in Turkey was that the National Highway Traffic Law provided exclusions from the mandatory seat-belt wearing provisions for certain vehicle occupants, certain classes of vehicles, and during certain driving manoeuvres. A comprehensive review of road traffic laws and regulation on speeding, seat-belt wearing and child restraint use was undertaken in 2011 (Öztürk, 2011). The review recommended the need for seat-belt wearing exemptions to be redressed and standards for child restraints to be put in place. The report noted that child restraints are not compulsory in vehicles that do not have

seat-belts. Seat-belt wearing exclusions included: drivers in commercial vehicles that transport passengers in urban areas; passengers in certain classes of minibuses and autobus that perform commercial passenger transportation; passengers who drive in reverse or who do not exceed 25 km/h; staff in military or police vehicles performing military or patrol exercises or serving as bodyguards; and emergency service staff on duty. The outcome of the report was used in a technical workshop that started a lengthy process for addressing these gaps in the Turkish traffic law. The ultimate goal was for these improvements to be addressed as amendments to existing laws.

As it happens in legislation change in many countries, legislative and regulatory changes at the national level in Turkey took a long time to be finalized. In the interim, an alternative was explored. Pending the changes in legislative and regulatory improvements the new Governor of Afyonkarahisar, Mr. Irfan Balkanlıoğlu, seized the opportunity to fast-track implementation of seat-belt wearing for all civil servants using an executive decree, also known as a circular¹ (Afyonkarahisar Governorate, 2012). The circular published in March 2012 required the following actions:

- police and government workers were to wear seat-belts at all times;
- the public was to be reminded about the need to obey all traffic laws;
- traffic police officers were to enforce seat-belt use and other laws and to do so uniformly, regardless of socio-economic class of road users;
- all public institutions and agencies were to serve as models for the public in complying with road traffic rules;
- managers of all institutions were to be responsible for the enforcement of the circular; and
- those who were fined for traffic offences would also be subjected to administrative investigation and action by the office of the governor.

¹ Circulars are binding and enforceable innominate regulatory acts permitted in Turkish Constitution. They can be issued by the offices of the prime minister, ministers and public legal entities to address specific issues provided for in the Turkish Law (Ceyhan, 2014).

The circular reiterated the principle that all citizens were equal before the law and helped to provide an interim solution to the exemptions from seat-belt wearing in the Highway Traffic Law. It also reinforced the commitment of the provincial government to implementing road safety measures.

Following the requirement by the new governor that enforcement was to start immediately, the following activities were quickly negotiated to get the revamped intervention off the ground:

- *Setting an implementation target and developing a joint plan of activities.* A plan of activities for 2012 was disclosed in a meeting attended by top managers (governor, mayor, head of city police department, university rector, provincial health director, provincial national education director, chairman of the trade chamber) and the press held on 27 March 2012. All provincial leaders and managers, including the governor, provided full support to the implementation of activities. Their support included discussing and making the issue known to the public, ensuring availability of staff, guaranteeing financial resources were allocated to the activities and undertaking constant review of progress. The target of the seat-belt wearing intervention was set as increasing the seat belt use rate among drivers and front seat passengers from less than 5% to 50% in Afyonkarahisar by the end of 2012. The new governor took the coordinating group and the traffic chief by surprise when he required that enforcement of seat-belt wearing should start sooner than expected, on 29 March 2012, and not in April as the coordinating group had planned (see Plate 1). The traffic police chief had to move fast to get traffic officers ready and checkpoints marked.



Plate 1: A project group meeting

Several activities, outlined below, had to be rushed. At the time, billboards were not even in place and details of the social marketing campaign had yet to be finalized.

- *Securing the support of traffic police officers and their families.* A meeting was held for the traffic police officers and their families to introduce the road safety project. The importance of wearing a seat-belt was explained and their support was reflected through the slogan: "police officers and their families to fasten seat-belts first."
- *Providing models of leading by example.* One of the principles advanced in policy change discourse is the need for an example of desired behaviour to be set by leaders and significant authorities who have influence on society. Following this principle, the Governor, Mayor, Head of the Police Department and Rector of Kocatepe University were used as role models regarding seat-belt use. Pictures showing them with fastened seat belts in their cars were used on billboards and the message that everyone should fasten seat belt was conveyed to the citizens in this way (see Plate 2). This strategy



Plate 2: Local leaders as role models

reinforced the fair approach principle of the project.

Plate 2: Local leaders as role models

- *Social marketing campaigns.* There were two main activities. The first was the production of a social marketing campaign with messages on seat-belt wearing. The second was the dissemination of the campaign, with a message informing the public about the conse-

quences of not wearing a seat-belt. The print media, television, and posters on billboards and buses were used as basic channels to disseminate these messages and the fact that wearing a seat-belt is a legal requirement. Results of pre- and post- 2010-2011 surveys on knowledge, attitudes and perception of the seat-belt wearing campaign have not yet been published in a journal but hopefully they will be in the future.

- *Demonstrating how a seat-belt works.* A seat-belt simulator was used to demonstrate to drivers how a seat-belt helps to prevent injury and death. Through collaboration with driving schools and police, all novice drivers were able to take practical sessions using a seat-belt simulator.
- *Enforcing road traffic law.* The traffic police were trained. They developed an enforcement plan which they consistently implemented.

What were the outcomes?

As shown in Figure 3, leveraging and interactions in a policy action situation are expected to lead to potential outcomes. We discuss these outcomes under three categories as presented in the methods section: process, intermediate and main.

Process outcomes

The process outcomes expected were preparing work plans, setting up national and local project working groups, planning and holding project meetings, reviewing and revising legislation on selected risk factors, conducting social marketing campaigns, conducting training, purchasing and delivering equipment, training police officers and enforcing traffic laws. A summary of process outcomes for the last five years of implementing the BPGRSP in Afyonkarahisar is presented in Table 1.

Indicator	Outputs
Project meetings	<ul style="list-style-type: none"> • Held regular meetings of national coordinating committee, local coordinating committee, working groups • Work plans developed every year • Several project implementation issues discussed and issues resolved
Changes in laws, regulations and/or decrees	<ul style="list-style-type: none"> • A circular mandating civil servants to wear seat-belts and requiring police enforcement. • Amendmen to the Highway Traffic law elimination key exemptions to the seat-belt wearing law (at national level). • Amendment drafted and under review by ministries to make other improvements in risk factors including drinking and driving and child-restraints (at national level).
Number of social marketing campaigns disseminated	<ul style="list-style-type: none"> • 2 (seat-belt wearing) • 1 (speed management)
Number of equipment purchased: seat-belt simulator	1

Table 1: Achievements in process outcomes in Afyonkarahisar

Source: Project documents and updates

Table 1 does not tell the full story of the interactions and decisions among partners. As shown in the previous section, there was an evolution in leveraging different centres of power, including securing the support of the Governor of Afyonkarahisar to issue a decree in March 2012 requiring all drivers to wear seat-belts. This evolution is associated with improvement in building trust and relationships among the partners. From a loose project group at the beginning in 2010, there emerged a network of actors, with a local project coordinating group that established procedures for operation and took ownership of the project. This coordinating structure provided a viable framework for interaction between the local level coordinating group and the national and international partners. For example, during a review of the project progress in an annual meeting of the project held in December 2013, a key representative of the Afyonkarahisar project coordinating group positively took feedback and discussion about a decline in the seat-belt wearing rate from 72.9% in June 2013 to 46.4% in October 2013. He promised to discuss the issue with the local coordinating group and reinforce actions on enforcement and social marketing campaigns. This type of positive receptivity to feedback was very different from the one seen at the November 2011 review meeting, when there was some reluctance by the then representative from Afyonkarahisar to fully accept results of the monitoring and evaluation. In 2011, the Afyonkarahisar representative disputed the figures presented by an external evaluation team, demanding to know more about methods and geographical spread of the evaluation.

With regard to approval of amendments to seat-belt wearing and speed management laws, there was an intense process of discussion and revision involving the national parliament and ministries. It took almost two years for the amendments to the seat-belt wearing law to be approved. The report which first identified the gaps was issued in 2012. However, changes to the law were only approved in February 2014, removing several of the previous exclusions including drivers and front seat passengers of ambulances, urban commercial passenger transportation drivers and public offi-

cial on duty. A traffic regulation on speed (Regulation 100) was also approved by the national parliament. It provided greater authority to local governments to change the speed limits for vehicles. Previously local governments could only increase the posted urban speed limit of 50 km/h by an additional 20 km/h; the change allowed local governments to increase the speed by an additional 32 km/h. In addition to amendments on speed and seat-belt wearing laws, in 2013, amendments to the traffic law were initiated in relevant ministries to reference standards applicable to use of the protective equipment (such as motorcycle helmets and child restraints that meet European Union standards), criminalize drinking and driving at 0.1 g/dl — blood alcohol content (BAC) limit of 0.05 g/dl, and impose penalties on individuals who refuse to have their BAC tested. These draft amendments have not yet been sent to parliament for action.

Like Afyonkarahisar, the governor of Ankara issued a circular in August 2012 requiring drivers and passengers to wear seat-belts as an interim measure while waiting for traffic law amendments (Governorship of Ankara, 2012). A major city with a population of over five million people, it was not realistic to implement the seat-belt plan throughout the entire city. Two municipalities were identified, the mayors were approached and willing to use their jurisdictional areas as demonstration sites. From these two sites, the seat-belt wearing promotion effort spread to the rest of the city. The experience of Afyonkarahisar was also used to plan for the second risk factor, speeding, in both Afyonkarahisar and Ankara. The actor networks developed were used to develop and implement a social marketing campaign and enforcement operations on speed management (with a campaign name “Think about the consequences, slow down your speed”) that was launched in December 2013.

At the national level, an unexpected policy outcome was that the Government of Turkey drew on the experience of Afyonkarahisar policy action situation to promote seat-belt wearing and speed management interventions in all the 81 provinces of the country. Turkey released its national Decade of Action for Road Safety plan in June

2013. One of the steps taken to promote this plan was to declare 2013 and 2014 as seat-belt wearing and speed management years. All 81 provinces in Turkey were asked to implement interventions on these two risk factors, drawing on the Afyonkarahisar experience. A further step taken by the Ministry of Interior was to identify 15 provinces to receive technical support and materials from BPGRSP Consortium partners in Turkey to implement measures on seat-belt wearing, speed and other risk factors during the Decade of Action for Road Safety: Adana, Bursa, Erzincan/Erzurum, Hatay, İstanbul, İzmir, Kayseri, Konya/Aksaray, Malatya/Elazığ, Sakarya/Kocaeli, Samsun/Amasya, Şanlıurfa, Sivas, Tekirdağ and Trabzon/Rize. A number of provinces followed Afyonkarahisar's example of issuing circulars as an interim measure while waiting for traffic law amendment. Provinces that also issued circulars were Antalya, Kocaeli, Samsun, Mardin, Erzincan, Amasya, Tekirdağ, Şanlıurfa and Sivas.

Intermediate and main outcomes

While qualitative measures and stories about policy change are important in highlighting relevant, complementary quantitative indicators of change are helpful for completing the assessment. As is common practice in policy implementation, the project coordinating group in Afyonkarahisar set a target to increase the seat-belt wearing rate among front seats (driver and passenger) from less than 5%, as reported at the end of 2011, to 50% by the end of 2012. One of the Consortium Partners, Johns Hopkins International Injury Research Unit, worked with a Turkish university to independently conduct observational studies to assess trends in behaviour and fatalities. These evaluators selected observational sites and carried out their observations without disclosing these details to those involved in implementing the social marketing campaigns and enforcement operations. The results of this assessment showed that seat-belt wearing rates increased from 3.9% to 36.8% in Afyonkarahisar over a five-year period of the intervention project (see Figure 7). Other outcomes under assessment are trends in road traffic deaths and serious injuries. We are hopeful that the findings

on both behaviour change and number of deaths will be available in scientific journals once Johns Hopkins International Injury Research Unit publishes them.

Conclusion

This paper has utilized Ostrom's concept of an action situation to examine how actors in different positions were leveraged to implement a road safety programme in Afyonkarahisar, Turkey. The findings suggest that sustained leveraging of and transacting with and among gatekeepers in road safety policy is necessary to sustain appropriate decision making and action taking within different institutions and administrative jurisdictions. The findings are in line with the slogan of the World Health Day in 2004 "Road safety is no accident," implying that it requires deliberate effort by the government and its many partners. The lesson here is a practical demonstration of how the science and art of road safety policy change play out through the collective action of different actors in a specific local context. We have mainly focused on the leveraging of influence and the transactions among partners. We hope that greater details on the methods and accompanying results regarding changes in road traffic fatalities, injuries, attitudes, perceptions and behaviour will be available or published in the future by project partners who have collected and analysed these data.

Acknowledgements:

This project was funded by Bloomberg Philanthropies. The authors thank Shivan Gupta, Connie Hoe and Nino Paichadze from the Johns Hopkins International Injury Research Unit for sharing information on seat-belt wearing rates and road traffic injuries. We are grateful to Natalie Draisin, Andrea Garfinkel-Castro, Zipporah Shanyisa Khayesi and David Khayesi for proof-reading and enhancing the readability of this paper. We also thank all the staff of local, national and international partners involved in planning and implementing BPGRSP in Turkey.

Author details:

Huseyin Akbulut,
Kocatepe University,
Department of Transportation,
Afyonkarahisar,
Turkey

Serap Sener,
World Health Organization,
Ankara,
Turkey

Fatih Vursavas,
Turkish National Police,
National Security Directorate,
Ankara,
Turkey

Corresponding author:
Meleckidzedek Khayesi,
World Health Organization,
Geneva,
Switzerland

Email:
khayesim@who.int

References:

- Adams, J. (1995) Risk. London: University College London Press.
- Afyonkarahisar Governorate. (2012) Road safety (Circular Note 2012/01). Afyonkarahisar.
- Banister, D. (2008) The sustainable mobility paradigm. *Transport Policy*, 15: 73-80.
- Belin, M-A. (2012) Public road safety policy change and its implementation: Vision Zero a road safety policy innovation [unpublished thesis for doctoral degree], Stockholm, Karolinska Institutet.
- Bergman, A. B., Gray, B., Moffat, J. M., Simpson, E. S. and Rivara, F. P. (2002) Mobilizing for pedestrian safety: an experiment in community action. *Injury Prevention*, 8: 264-267.
- Bloomberg Philanthropies. (2012) Leading the worldwide movement to improve road safety 2010-2012. New York City: Bloomberg Philanthropies.
- Bliss, T. and Breen, J. (2009) Country guidelines for the conduct of road safety management capacity reviews and the specification of lead agency reforms, investment strategies and safe system projects. Washington, D.C.: World Bank.
- Bugeja, L., McClure, R. J., Ozanne-Smith et al. (2011) The public policy approach to injury prevention. *Injury Prevention*, 17: 63-65.
- Canoquena, J.M. da. C. (2013) Reconceptualising policy integration in road safety management. *Transport Policy*, 25: 61-80.
- Capano, G. (2009) Understanding policy change as an epistemological and theoretical problem. *Journal of Comparative Policy Analysis: Research and Practice*, 11(1): 7-31.
- Capano, G. and Howlett, M. (2009) Introduction: The determinants of policy change: Advancing the debate. *Journal of Comparative Policy Analysis: Research and Practice*, 11(1): 1-5.
- Ceyhan, M. (2014) The Status of "Circulars" in Turkish Law and Evaluation regarding Practice. Istanbul.
- Elvik, R., Høy, A., Vaa, T. et al. (2009) The handbook of road safety measures. Bingley: Emerald Group Publishing Limited.
- Esiyok, B., Korkusuz, I., Canturk, G. et al. (2005). Road traffic accidents and disability: A cross-section study from Turkey. *Disability and Rehabilitation*, 27(21): 1333-1338.
- Frattaroli, S., Defrancesco, S., Gielen, A. C. et al. (2006) Local stakeholders' perspectives on improving the urban environment to reduce child pedestrian injury: implementing effective public health interventions at the local level. *Journal of Public Health Policy*, 27(4): 376-388.

- Glasgow, R. E., Lichtenstein, E. and Marcus, A.C. (2003) Why don't we see more translation of health promotion research to practice? Rethinking the efficacy-to-effectiveness transition. *American Journal of Public Health*, 93(8): 1261-1267.
- Governorship of Ankara. (2012) Road safety project (B.05.1.EGM.4.06.(6844)-63232 İda.Hiz.Br.A. R). Ankara.
- Hyder, A. A. (2013) Injuries in low- and middle-income countries: a neglected disease in global public health. *Injury: International Journal for the Care of the Injured*, 44: 579-580.
- Hyder, A.A., Allen, K.A., Di Pietro, G. et al. (2012) Addressing the implementation gap in global road safety: Exploring features of an effective response and introducing a 10-country program. *American Journal of Public Health*, 102(6): 1061-1067.
- Hyder, A. A., Bishai, D. (2012) Road safety in 10 countries: A global opportunity. *Traffic Injury Prevention*, 13(S1):1-2.
- Insurance Institute for Highway Safety. (2011) Low-hanging fruit. *Status Report*, 46(7): 1-7.
- Lane, J.E. (1983). The concept of implementation. *Statsvetenskaplig tidskrift*, 86: 17- 40.
- Levin, K., Cashore, B., Berstein, S. et al. (2012). Overcoming the tragedy of super wicked problems: constraining our future selves to ameliorate global climate change. *Policy Sciences*, 45: 123-152.
- Lyons, R. A., Kendrick, D., Towner, E. M. L. et al. (2013) The advocacy for pedestrian safety study: cluster randomised trial evaluating a political advocacy approach to reduce pedestrian injuries in deprived communities. *PLoS ONE*, 8(4): e60158. doi:10.1371/journal.pone.0060158.
- McGinnis, M. D. (2011) An Introduction to AID and the Language of the Ostrom Workshop: A Simple Guide to A complex Framework. *Policy Studies Journal*, 39(1): 169-183.
- Meadows, D. (1999) *Leverage Points: Places to intervene in a System*. Hartland: The Sustainability Institute.
- Milder, C.J., Gupta, S., Özkan, T. et al. (2013) Predictors of intrinsic motivation behind seatbelt use in a country where current use is low. *Injury: International Journal for the Care of the Injured*, 44(supplementary 4): S57-S63.
- Ostrom, E. (2010) Beyond markets and states: polycentric governance of complex economic systems. *American Economic Review*, 100(3): 1-33.
- Öztürk, E. A. (2011). Road safety in 10 countries: highway traffic legislation in Turkey. Ankara: Gazi University: Department of Traffic Planning and Implementation.
- Pasanen E.(1991) *Ajonopeudet ja jalankulkijan turvallisuus [Driving speeds and pedestrian safety]*. Espoo, Tekniil-linen korkeakoulu, Liikennetekniikka.
- Peden, M., Scurfield, R., Sleet, D. et al. eds. (2004) *World report on road traffic injury prevention*. Geneva: World Health Organization.
- Peden, M. (2010) Road safety in 10 countries. *Injury Prevention*, 16(6): 43.
- Peden, M., DiPietro, G., Hyder, A. A. (2012). Two years into the road safety in 10 countries project: how are countries doing? *Injury Prevention*: doi: 10.1136/injuryprev-2012-040432.
- Peltzman, S. (1975) The effects of automobile safety regulation. *Journal of Political Economy*, 83(2): 677-726.
- Plowman, D. S., Baker, L. T., Beck, T. E. et al. (2007) Radical change accidentally: the emergence and amplification of small change. *Academy of Management Journal*, 50(3), 515-543.
- Puvanachandra, P., Hoe, C., Özkan, T. et al. (2012) Burden of road traffic injuries in Turkey. *Traffic Injury Prevention*, 13 (sup1): 64-75.

Rittel, H. W. J. and Webber, M. M. (1973). Dilemmas in a general theory of planning. *Policy Sciences*, 4:155-169.

Rosén, E., Stigson, H. and Sander, U. (2011) Literature review of pedestrian fatality risk as a function of car impact speed. *Accident Analysis and Prevention*, 43: 25–33.

Tansel, A. (1989) Factors affecting Traffic Accidents in Turkey. *Approaches to Regional Transport Problems: Middle East Requirements, International Symposium, Istanbul, 23-26 May 1998.*

Treviño-Siller, S., Hajar, M. and Mora, G. (2011) Prioritisation of road traffic injury interventions: results of a participative research with stakeholders in Mexico. *International Journal of Injury Control and Safety Promotion*, 18(3): 219-225.

Wilde, G. J. S. (1982) The theory of risk homeostasis: implications for safety and Health. *Risk Analysis*, 2(4): 209-225.

World Health Organization. (2013) *Global status report on road Safety: Supporting a Decade of Action.* Geneva: World Health Organisation.

Zohlnhöfer, R. (2009) How politics matter when policies change: Understanding policy change as a political problem. *Journal of Comparative Policy Analysis: Research and Practice*, 11(1): 97-115.

Will the government's spending on expanding the national road network deliver anything useful? Have they properly taken into account induced traffic and extra congestion likely to be caused elsewhere?

John Elliott

1. Introduction

There is very strong evidence (but not as widely known as it should be) that road building can increase traffic levels enormously within a few years of opening and is likely to cause more congestion in the area rather than reducing it. Mechanisms which can account for a substantial proportion of the additional traffic are mode and destination change. These are often modelled for larger schemes but rarely do the results of the modelling reproduce what actually happened after opening. Occasionally land use effects are modelled though usually are not; completely new trips and peak narrowing are sometimes mentioned qualitatively. Psychological and social mechanisms are not usually in the competence of traffic models.

Transport planners who want to make estimates of induced traffic can now make an attempt, however this does not appear to correlate well with observations and past experience. Any comparison can be disguised by including an element of 'natural traffic growth' which is usually assumed to be the same with or without a scheme.

Extra traffic induced by a scheme will inevitably cause extra congestion at the ends of the new roads (often in urban areas where congestion is at its worst in any case) from the extra traffic. Although the extra traffic and congestion is very visible and usually actually appears 1-5 years after opening, it is seldom quantified or assessed properly.

The December 1994 SACTRA report 'Trunk Roads and the Generation of Traffic' (SACTRA, 1994) is probably the most robust evidence and analysis of all this. The SACTRA work itself pulled on a number of different evidence sources - not only the before-and-after traffic counts but also inferences from large numbers of studies of values of time, demand elasticities, differential growth rates, and surveys. It

was because all these told a broadly consistent story that SACTRA felt able to be more decisive in its conclusions than the Department of Transport was expecting at the time.

Since then there has been one completely different type of evidence base as well: this is the complementary literature on traffic reduction following road space reductions (pedestrianisation, bus lanes, disasters, maintenance closures, etc). This is important in its own right, but also significant in giving confidence that the induced traffic effect is not an artefact due to economic growth or similar. The largest empirical compilation is a book Traffic Impact of Highway Capacity Reductions (Cairns et al, 1998) with some updating papers subsequently of which one was awarded a gold medal by the Institution of Civil Engineers.

SACTRA does show that the net effect of road enlargements could actually create more congestion. Mogridge and Thompson really propounded this in their various books and technical papers (Mogridge, 1997; Thompson, 1969; Thompson, 1977) and it certainly can apply most in big cities on radial routes. Explained simply there is a vicious circle --- more road space - more car use - less public transport use - fares go up, frequency goes down - more people transfer to cars etc and the new equilibrium point is a lower level of service in both cars and Public Transport.

In addition to SACTRA (1994) there are a number of other sources on this subject:

- John Elliott's 1985/6 original work with colleagues at GLC which was republished in WTPP (Purnell et al, 1999). This work was also part of a submission by John Elliott and Derek Turner in 1987/8 to the House of Commons Transport Committee Inquiry into major roads on behalf of the Association of London Borough Engineers and Surveyors (the precursor to the London division of the Local Government Technical Advisers Group - LoTAG). No electronic reference can be found for this.)
- A report done for CPRE and others in July 2006 (CPRE, 2006) called 'Beyond Transport Infrastructure'

- An article by Phil Goodwin (Goodwin, 2006) titled 'Induced traffic again. And again. And again' with the editor's comment "(Don't lose this - we might need to publish it again in 2014 - ed)" (please see below why the editor makes this comment)
- A paper presented by John Elliott and an Australian academic (Zeibots and Elliott, 2010) titled 'Urban road building and traffic congestion: What went wrong?'
- Evidence from the M25 and other roads that is clearly visible to anybody - When the western arm of the M25 was widened from 3 to 4 lanes it was reported that traffic increased by 33% in a year (exactly the same as the capacity increase!). A similar experience occurred with hard shoulder running on the M42. Unfortunately both these studies seem to have disappeared from any references.

2. Analysis

It is interesting to note that SACTRA was appointed and given terms of reference by a Conservative Government, which was also in place when its 1994 report was published. The author recalls the then Transport Minister Stephen Norris saying in a short speech at the time that the government would not have built so many roads if they had known about it. (Stephen Norris is aware that his statement has been repeated by the author of this paper)

While this gives robust evidence of roads generating traffic there is also substantial evidence that extra road space and higher speeds do not necessarily provide economic benefits. Reference can also be made to the 1999 SACTRA (SACTRA, 1999) report on roads and the economy which included doubts that the economic benefits could be as high as the calculated time savings. We also know that the 'economic benefits' calculated largely on basis of predicted time savings are highly artificial (Elliott, 2015). The author outlined his basic criticisms of the 'economic assessments' in the following terms:

" --- However linking models (which have been highly calibrated or 'adjusted' to try and match a base year situa-

tion) to predict behaviour change with an economic assessment introduces potential for a highly distorted view of the potential benefits to real travellers or the economy.

Within the 'economic assessment process there are the following major issues:

-The evaluation is largely based on the difference between two enormous sums of time spent on the network with and without a scheme; each of these sums is based on a large number of assumptions, the process is therefore mathematically very unsound.

-For major road schemes most of the 'benefits' appear for the peak traffic times (i.e. largely for car commuting - a mode and time that most highway and planning authorities do not want to encourage - it is noted that the very recent increase in the value of time for commuting is likely to further exacerbate this problem) and for the period 30-60 years in the future (where the assumptions taken are even less real).

The impact of 'generated' traffic compared with the so called 'natural traffic growth' and its impact outside the proposed scheme is never adequately considered (seldom do the models predict the level of generated traffic caused by the new road fully, also the extra generated traffic causes minor extra widespread congestion and delays outside the immediate study area, this is usually modelled without the junctions and without other traffic that passes through that area but not through the study area - delays at junctions in urban areas increase very rapidly with small increases in traffic."

It appears that the statements of certain business people and the roads lobby, is being used to make the case for Strategic Road improvements rather than any evidence. It is an easy message to say that widening a road would appear to be a solution to congestion especially from behind the steering wheel of a car in a traffic queue! The real message on transport policy is much more complicated.

Rather than using my own words to describe the history, analysis and effects of generated or induced traffic it is perhaps

pertinent to look at Goodwin's (2006) where he reviewed the literature on this subject, gave practical information but also more than justifying his title: "Induced traffic again. And again. And again". Goodwin (2006) and Purnell et al (1999) noted the long history of reports of induced traffic. As far back as 1925 it was identified that the opening of a new section of the Great West Road caused a massive increase in traffic. In Bressey's report of 1937 it stated "the remarkable manner in which new roads create new traffic". According to the study, immediately after the Great West Road was opened in 1925 it "carried 4 1 / 2 times more vehicles than the old route was carrying; no diminution, however, occurred in the flow of traffic along the old route,".

Goodwin (2006) refers to a number of times when newly generated traffic had been reported and its extent confirmed, even appearing in Ministry advice, but every time the issue has been 'forgotten' for a number of reasons. He states:

"So 1925, 1937, 1958, 1963, 1968, 1985, 1987, 1988, 1994, 1996, now 2006: for eighty years, every eight years on average there has been the same experience, the same conclusions - even, for goodness sake, more or less the same figures. The evidence has been consistent, recurrent, unchallenged by serious countervailing evidence, but repeatedly forgotten."

This recurrence about every eight years explains why LTT's editor suggested Phil Goodwin's article should be republished in 2014.

In 1985 the GLC team showed every major road constructed in London between 1966 and 1985 generated phenomenal amounts of extra traffic; for example Westway corridor was carrying nearly double the all-day traffic within five years of opening and the peak flows on Blackwall Tunnel doubled in less than a year. The full details are available in Purnell et al (1999); however a later version of the 1985/6 GLC report (no longer available) did investigate modal split impacts on the M11 corridor indicating significant modal shifts from rail to car and rail heading on the tube network. It

is notable also in this GLC publication that 'natural traffic growth' is minimal in areas without road enlargements.

SACTRA (1994) published its best known report, on what it renamed 'induced' traffic. The average traffic flow on 151 improved roads was 10.4% higher than forecasts which omitted induced traffic, and 16.4% higher than forecast on 85 alternative routes that improvements had been intended to relieve. In a dozen more detailed case studies the measured increase in traffic ranged from 9% to 44% in the short run, and 20% to 178% in the longer run. This fitted in with other evidence on elasticities, and aggregate data. The conclusion was:

"an average road improvement, for which traffic growth due to all other factors is forecast correctly, will see an additional [i.e. induced] 10% of base traffic in the short term and 20% in the long term"

The CPRE report (CPRE, 2006) looked in detail at three big schemes on the A27, A34 and M65, and a further ten schemes on the A5, A6, A41, A43, A46, A66, A500 and A1033. These were schemes undertaken 8 years after SACTRA's 1994 report had been finished and accepted. The report included some telling statements:

"Careful scrutiny of the traffic flow data suggests that traffic growth after the scheme opened has been significantly higher than growth on other nearby road corridors or national traffic growth"

"...in all three case studies the current traffic flows are near or already in excess of what was predicted for 2010. In towns with bypasses, such as Newbury and Polegate, the new roads did significantly reduce the town centre traffic levels. However, these reductions are not as great as originally forecast and there has subsequently been regrowth in traffic levels on the bypassed roads. The net effect in combination with the new road is generally a considerable overall increase in traffic".

After noting the Highways Agency's own explanations for the extra traffic growth, (which were intriguingly similar to those rejected by SACTRA 12 years earlier - including wide area reassignment), the report states:

"Nevertheless, in view of the fact that many of the schemes reviewed have demonstrated significant increases in traffic volumes (in the range of 10-35%, within a period of one to two years after opening), there would seem a strong case to consider the issue of induced traffic in more detail in future evaluations".

This last published study did not include schemes near London or major conurbations. Since the GLC 1985 study there have been a number of schemes on the North Circular Road, the completion of the M25 and major enlargements of radial routes - the M40/A40, A13, M1, M2/A2, A41. As a user of most of these routes over the period since 1985 it is notable how volumes changed after the enlargements were carried out. It is also interesting to note Phil Goodwin's comment on the M25:

"in 1988 after the M25 exceeded its long term forecast traffic growth within months of opening."

3. Concluding comments

In 2010 Zeibots and Elliott using Australian and UK evidence concluded:

"When taken as a whole, there appears to be a cycle at play where road expansion is advocated to overcome congestion; people in affected neighbourhoods object, saying they want public transport to be improved instead; governments react to public complaint; road expansion policies are put on hold and new policy directions are investigated; congestion continues to be a problem, and; eventually road expansion policies creep back into government transport plans so that the cycle begins again. In light of this history, we ask why government administrations in the UK and Australia, and other parts of the world, have continued to increase road capacity as a solution to

congestion when all the evidence indicates it generates additional traffic that perpetuates congested conditions?"

Many of the road schemes presently being proposed by the government are in the vicinity of cities and conurbations, in places where it is recognised that there is serious congestion. However all the evidence suggests that enlarging roads in such places will increase traffic and is likely to cause more congestion in the area, rather than reducing it, within a very few years. Even the arguments on calculated or predicted economic benefits seem very spurious indeed.

While many Transport Planners, especially those who might read WTPP journals, are well aware of the level of induced traffic and its consequences, government should also be well aware and be adjusting policies accordingly. It should be noted that the Local Government Technical Advisers Group has outlined these issues to government on a regular basis - the last occasion was in December 2014 to the House of Commons Scrutiny Committee on the Infrastructure Bill.

Acknowledgement:

The author's thanks to Phil Goodwin for his advice on the understanding of the workings of the 1994 SACTRA review and the use of text from his 2006 article in Local Transport Today.

Author details:

John Elliott BSc, CEng, MICE, FCIHT, MCMI. Vice Chair National Transport Committee and Communications Officer for the Local Government Technical Advisers Group and Independent Consultant.

Email:

johnreliott@btinternet.com

References:

Bressey, C.H. (1937) Highway Development Survey HMSO, London

Cairns S, Hass-Klau C and Goodwin P (1998) Traffic Impact of Highway Capacity Reductions: Assessment of the Evidence, Landor Publishing, London, ISBN 1 899650 10 5

CPRE (2006) Beyond Transport Infrastructure by Matson, L, Lynn Sloman, Ian Taylor, and John Elliott (2006)

Elliott, J (and others) 2015, Modelling: misuses, mistakes and misconceptions - Local Transport Today 686 27th November – 10th December 2015.

Goodwin, P (2006) Induced traffic again. And again. And again published in Local Transport Today August 2006. (Full wording can be found on <http://www.lgtag.com/index.php/news/566-tag-evidence-to-hoc-scrutiny-committee-on-infra-structure-bill> see Appendix 3.

Local Government Technical Advisers Group December 2014 to the House of Commons Scrutiny Committee on the Infrastructure Bill. Please see: <http://www.lgtag.com/index.php/news/566-tag-evidence-to-hoc-scrutiny-committee-on-infra-structure-bill> and particularly Appendix 3.

Mogridge, M (1997) The self-defeating nature of urban road capacity policy: A review of theories, disputes and available evidence , Volume 4, Issue 1, January 1997, Pages 5–23 1997 Elsevier Transport Policy Journal

Purnell, S, Jillian Beardwood and John Elliott (1999) The Effects of Strategic Network Changes on Traffic, published by GLC in 1985/6 and republished in World Transport Policy and Practice, 5, 2, 28-48 <http://worldtransportjournal.com/wp-content/uploads/2015/02/wtpp05.2.pdf>

SACTRA (1994) The Standing Advisory Committee on Trunk Road Assessment Trunk Roads and the Generation of Traffic. Chairman Mr DA Wood QC December 1994 HMSO ISBN 0 11 551613 1

SACTRA (1999) Standing Advisory Committee on Trunk Road Assessment Transport and the economy (http://webarchive.nationalarchives.gov.uk/20050301192906/http://dft.gov.uk/stellent/groups/dft_econappr/documents/pdf/dft_econappr_pdf_022512.pdf)

Thompson, M (1969) Motorways in London, London Amenity Transport Association

Thompson, M (1977) Great Cities and Their Traffic, Victor Gollancz Ltd 1977 ISBN 0 575 02146 2

Zeibots, M and John R. Elliott (2010) Urban road building and traffic congestion: What went wrong, World Transport Policy and Practice, 17, 3, 6-26 <http://worldtransportjournal.com/wp-content/uploads/2015/02/wtpp17.3.pdf>

Streets of yesterday, today, and tomorrow

Joseph Kott

1. Introduction

Just as streets connect, albeit sometimes divide or sever, neighborhoods and districts of a city (Bradbury, Tomlinson, & Millington, 2007), the study of streets joins together several realms of inquiry often disconnected from one another.¹ As shown on Figure 1, knowledge pertaining to streets resides in many disciplines.

Research into streets is part of the quest for a more comprehensive understanding of what makes our cities and regions livable. The street provides a connection to the wider world while also offering a venue for many of life's activities.

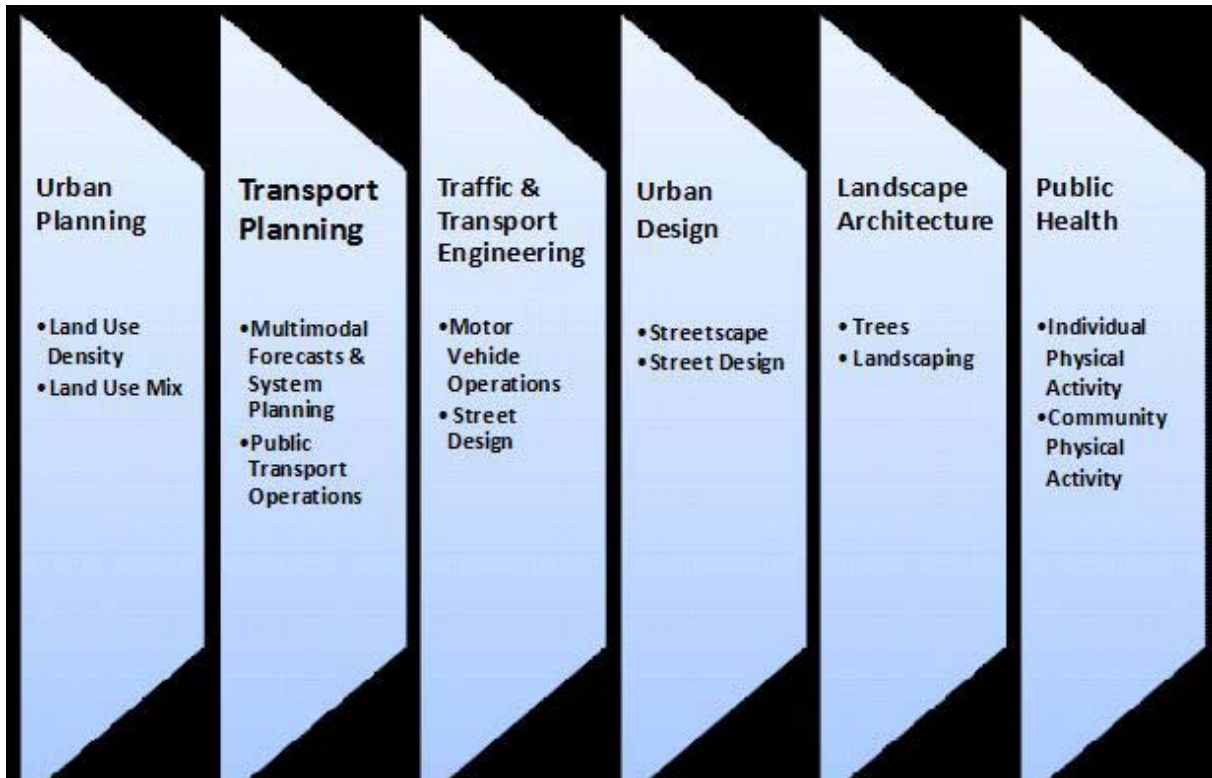

Figure 1. Disciplinary Domains Pertaining to Streets

Pathways of inquiry into streets are diverse. Some of the most important are the built environment (land use, transport systems, street front), urban design (streetscape, provision for nature), socio-economics (demographics, incomes, employment), socio-cultural (cultural norms, peer and family influences on street users), and the psychology of individuals (perceived comfort, safety, and satisfaction of street users). Figure 2 shows the observable influences on streets.

¹ Kott, J. (2012). Streets of clay: design and assessment of sustainable urban and suburban streets. [Doctoral dissertation]. Retrieved from http://espace.library.curtin.edu.au/R?func=dbin-jump-fu-ll&local_base=gen01-era02&object_id=171640

2. Streets in history

Streets have existed since the appearance of human settlements. The first streets, built of limestone and raised above the ground, may have appeared at Khirokitia in what is now Cyprus some eight thousand years ago. The first sidewalks, or pavement dedicated to pedestrians as a street design feature, may have been built at Kültepe in Asia Minor about four thousand years ago (Kostof, 1992, pp. 176-177). Ancient Rome had three types of streets: itinera exclusively for pedestrians, actus for a single cart at a time, and viae for two carts, side-by-side (Gunnarsson, 2004, p. 1).

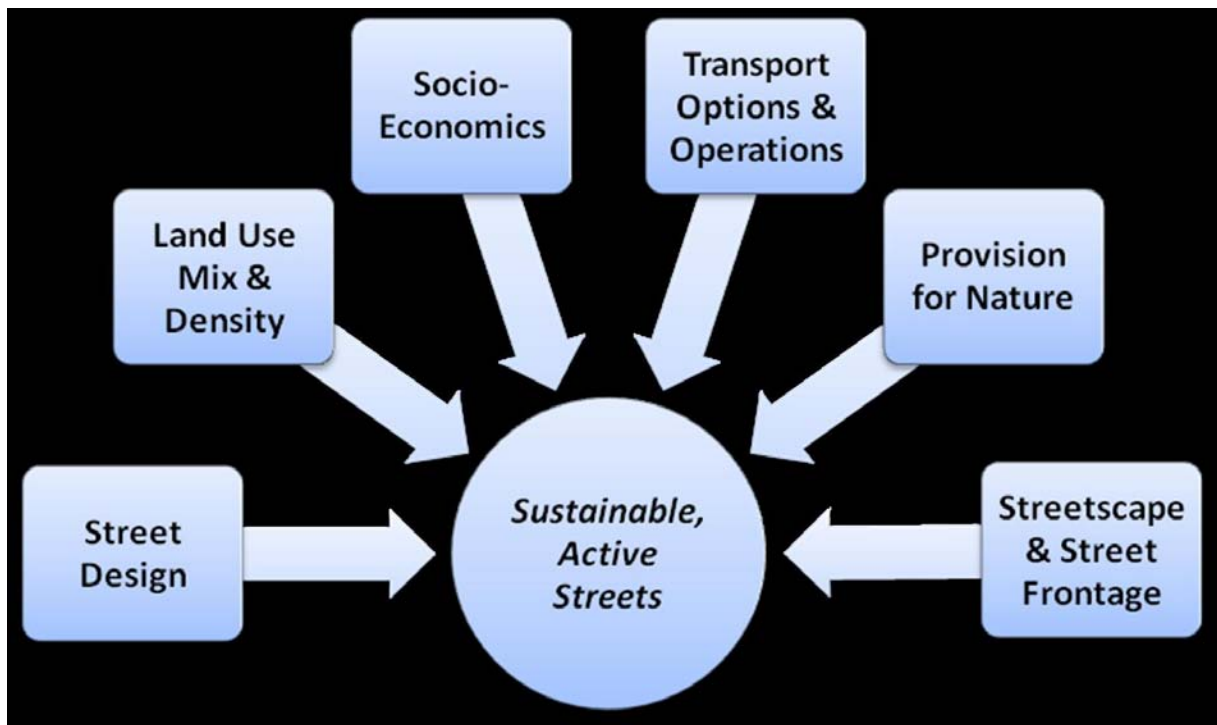

Figure 2. Visible, Measurable Influences on Streets

Gehl (2006) points out that “in the entire history of human settlement, streets and squares have been the basic elements around which all cities were organized”. Thus, they “constitute the very essence of the phenomenon ‘city’”. Streets are “based on the linear pattern of human movement” and squares on “the eye’s ability to survey an area” (Gehl, 2006, p. 89). In the words of the noted British scholar of streets and street patterns, Stephen Marshall (2009), “the arrangement of cities in streets is not just about physical circulation, but is inextricable from the very concept of a city” (p. 111). Grava (2003) notes that streets began simply as “linear spaces left between building lines”. In these spaces urban life in all its variety unfolded in animated ways: “People, carts, and animals used the same channels, mixed freely, and were all impeded by the many activities that spilled out onto the street ... peddlers, vendors of food, purveyors of various services, entertainers, musicians, preachers, children, thieves, and beggars” (pp. 15-16).

The conflict around hierarchy of street use is an important theme in scholarship on the evolution of streets, as well as in the professional cultures of transportation and traffic engineering, urban planning, and urban design (Brown, 2006; Hebbert, 2005; Hess, 2009; Lillebye, 2007; Marshall, 2005; McShane, 1994). In the words

of one of the most celebrated students of the street, Donald Appleyard (1987): “The streets have always been scenes of conflict. They are and always have been public property, but power over them is ambiguous, for the street has an open and easily changeable nature” (p. 9). Similarly, from his generative work on the effects of street traffic on residential life (Appleyard, et al., 1981), Appleyard contends: “The street has always been the scene of ... conflict, between living and access, between resident and traveler, between street life and the threat of death” (p. 1).

3. Street purposes

For Anderson (1986), streets have an intermediate position in cities, towns, and villages, “intersecting public and private, individual and society, movement and place” (p. 1). Rykwert (1986) describes them as “human movement institutionalized”. As defined by Kostof (1992), streets are “human intercourse institutionalized” (p. 189). Marshall (2005) sees them as having “multiple personalities ... a variety of different characteristics that are present simultaneously” (p. 23). In the words of David Engwicht (1999), the Australian cultural planner, activist and advocate of traffic calming, streets provide “a dual space for both movement and exchange” (p. 19). Gehl and Gemzoe (2003) have pointed

to three roles for streets and squares: "meeting place, marketplace, and traffic space" (pp. 97-98). Marshall (2005) has observed that the street can be defined to be either "a road that happens to have an urban character, or as an urban place, that happens to serve as a right of way" (p. 22). Allan Jacobs (1993) has portrayed the street in kinetic terms: "The street is movement: to watch, to pass, movement especially of people: of fleeting forms and faces, changing patterns and dress" (p. 4). For Jane Jacobs (1961), "streets provide the principal visual scenes in cities" (p. 378). Similarly, in the conceptual framework of the urban design theorist Kevin Lynch (1960), streets are "paths" or "channels along which the observer occasionally, or potentially moves"; moreover, "people observe the city while moving through it" (p. 47). Allan Jacobs (1993) also sees streets as "places of social and commercial encounter and exchange" that "allow people to be outside" (p. 4). Moule and Polyzoides (1994), saw streets as "communal rooms and passages" (p. xxii).

Jane Jacobs (1961), in her influential critique of modernist American city planning, described streets and their sidewalks as "the main public places of a city ... its most vital organs" (p. 29). Their "fundamental task" was keeping a city safe, largely, in her famous phrase, by people on them providing "eyes upon the street" (pp. 30, 35). Beyond catering to the demand for movement and providing surveillance, Mehta (2006) observes that streets may also be "a place for shopping, play, relaxation, and social interaction" (p. 170). To Lillebye (2007), streets function as "an element of urban form, a communal arena, a cultural arena, and a social arena" (p. 2).

For Marshall (2003), the street is "an important integrating component ... not only as a physical movement channel and built form but also as a public space, a place of cultural identity, setting for social and economic activity, and indeed contributor to urban equity and sustainability" (p. 771). Marshall (2003) concludes that, "the street is fundamentally a means of organizing activities around a pattern of circulation" (p. 772). In the view of Kostas (1992), "traffic, the exchange of goods, and social exchange and communication"

are the traditional purposes of streets (p. 189).

Marshall (2003) expresses the teleology of the street in these terms: "The street essentially embodies three dimensions in a single package: as a transport route or artery for through movement; ... as a public space, where a variety of human activities take place; and ... as a built frontage" (p. 771). How street space is, could, and should be allocated among these functions or dimensions, has long been the subject of lively debate and dispute (Appleyard, 1987; Kostof, 1992). Jane Jacobs (1961) described the competition for the street in this way: "Vehicles compete with each other for space and for convenience of their arrangements. They also compete with other uses for space and convenience" (p. 349).

The competition for allocation of street functions is a contest about the city or region-wide functions of a street, the district or neighborhood role of the street, and the micro-scale function of street frontage and streetscape. Such competing demands are inherently difficult to meet and have given rise to a huge body of research across many disciplines. To add further complexity, Hawkes and Sheridan (2009) have even contended that streets are de facto "land banks" and, as such, are "the ultimate untapped urban resource ... that is waiting to be cashed in", implying the need for a fundamental re-allocation of street space (The Great Opportunity section, ¶1). The street, that most ordinary public utility, is not only useful, but also complex and imbued with potential.

Arterial streets have both an "arterial role" and an "urban place role" (Marshall et al., 2004, p. 4). Jones et al. (2007a) note that the link function of an arterial street "serves to enable users to pass through the street as quickly and conveniently as possible" and the place function "seeks to encourage users to stay as long as desirable on a street and enjoy the street's surroundings" (pp. 20-21). Marshall (2003) partitions street functions into a "transport axis" and a "people axis". Activities on the transport axis include car driving and parking, goods vehicles driving and servicing, public transport operations in movement

or dwelling at stops, cycles (motorized and non-motorized) cycling and parking, and pedestrians walking "in transit from A to B" (Marshall, 2003, p. 776).

4. Streets as places

Much of the social and economic life in cities takes place on the streets, arterial or otherwise. For Appleyard, et al. (1981), "the social relations that take place on the street, its potential for neighborliness and street life, are values of urban life to be treasured" (p. 9). To Kostas (1992), "there are intricate levels of social engagement encouraged and hosted by the street structure" (p. 189). Jane Jacobs (1961), ever quotable, summarized the social role of city street sidewalks in these remarkable terms: "Lowly, unpurposeful and random as they may appear, sidewalk contacts are the small change from which a city's wealth of public life may grow" (p. 72).

She described four conditions necessary for streets to produce "exuberant diversity": a mixture of land uses to provide "the presence of people who go outdoors on different schedules ... for different purposes"; short blocks that yield "opportunities to turn corners"; a close-grained mingling of buildings varying in age and condition; and a sufficient concentration of people, including residents (J. Jacobs, 1961, pp. 150-151). There was a synergy between residents and workers that produced more than the sum of their parts (J. Jacobs, 1961, p. 153). Her prescriptions for creating and maintaining streets that feed the economic and social life of cities and sustain city livability are inductive and ad hoc, a product of inspired intuition rather than formal analysis. There is also a "social logic" in city streets. As Stephen Marshall (2009) has written: The way that cities are laid out with public streets and private plots and buildings allows that right mix of surveillance, anonymity, personal control of own space, and so on, that make this space suitable for people who do not know each other. Basically, it allows a city to exist as a container for strangers. (p. 110). As such, Marshall (2009) contends, "the social space of streets is the single contiguous public space off of which private spaces are carved" (p. 110).

Danish urban designer Jan Gehl (2006) contends that, "when traffic is slow there is life in the streets for this reason alone" (p. 77). If movement speeds on a street are reduced from 60 to 6 kilometers per hour, for example, there will appear to be ten times the number of people on the street since "each person will be within visual range ten times longer". Public spaces in cities, including streets, can invite social activity when "external conditions for stopping and moving about are good". These conditions, according to Gehl, include protection from crime, vehicular traffic, and unpleasant weather (Gehl, 2006, pp. 171-173). Aesthetic considerations or "the design of the space", as well as a "sense of place" inspired by architectural quality support and complement the external conditions related to comfort (Gehl, 2006, p. 181).

The economic life of urban commercial and mixed-use streets constitutes a kind of marketplace. Allan Jacobs (1993) described this aspect of street life as follows:

Some streets are for exchange of services and goods; places to do business. They are public showcases, meant to exhibit what a society has to offer, and to entice. The entrepreneur offers the goods, displays them, comes out onto the street as much as will be allowed, with wares to be seen. The looker sees, compares, fingers, discusses with a companion, and ultimately decides whether to enter the selling environment or not, whether to leave the anonymity and protection of the public realm and enter into private exchange (p. 4).

Jones et al. (2007b) noted that commerce on many such streets sprung up because they were "key points on the urban road network, where businesses have been able to access a larger customer base than can be provided by the local community" (p. 63).

Gehl (2006) concludes that the duration of stay influences the level of social activity on streets and in other public spaces: "If people are tempted to remain in public spaces for a long time, a few people and a few events can grow to a considerable

activity level" (p. 79). People participating in one event or situation have an opportunity to participate in another, so that "a self-reinforcing process can begin" (Gehl, 2006, p. 81). Lengthy stays lead to lively streets. Public spaces of poor quality have "only the bare minimum of activity". In contrast, within good quality public spaces "a broad spectrum of human activities is possible" (Gehl, 2006, p. 11). The quality of "space between buildings" on streets and squares contributes to "living cities, ones in which people can interact with one another" (Gehl, 2006, p. 21).

5. Street design

Jones et al. (2007a) identified a variety of street planning and design qualities important to the "vitality and viability of shops and businesses". A high degree of accessibility "at a city level, by all modes of transport" is essential for major retail streets. Integration into surrounding residential street networks is important for high streets in local centers. A variety of "retail, professional and public services" affords synergy in use of the street for multiple activities. Provision for both through movement and "interchange for people on foot, using bicycles, private vehicles or public transport" fosters accessibility and generates activity. Attractive street design that appeals to those "strolling, window shopping and visiting market stalls or pavement cafes" promotes business vitality along with quality of life (Jones et al., 2007a, p. 31).

Svensson (2004) maintains that, "while it is relatively straightforward to design either a main road catering primarily for traffic movement or a street for urban activities, it is not so easy to combine the main road function and urban functions in the design of a sustainable arterial street" (p. 5). She also notes that there are "two separate compatibility issues that need to be resolved in the act of (street) design". These are the "physical fit – or the ability to accommodate space for different uses" and "compatible use – the suitability for different uses to be located next to or mixed with each other" (Svensson, 2004, p. 50). In the words of American urban designer Elizabeth Macdonald (2007), "ecologically and socially responsible street

design calls for balancing how the public space of streets is used" (p. 27).

Kubilins (1999) called upon traffic engineers to "refocus on modal choices: pedestrians, bicycles, automobiles, and transit" by stressing the importance of relative speed in the design of "functional streets that contribute to our quality of life" (p. 1). She argued that "relative speed is the key to safe, multimodal streets" and that "land use and transportation must work in harmony" (Kubilins, 1999, p. 2). The importance of design speed for streets was apparent when comparing driver reaction and braking distance at 40 mph, about 300 feet, to only 100 feet at 20 mph (Kubilins, 1999, p. 3). Moreover, "the probability of a pedestrian being killed when a vehicle is -travelling at 15 mph is 3.5%, compared to 37% at 31 mph, and 83% for a vehicle traveling at 44 mph" (Kubilins, 1999, p. 4).

The author of an authoritative report on context sensitive street design for major urban thoroughfares (Daisa, ITE, 2006) argues that "thoroughfare design should complement urban buildings, public spaces and landscape, as well as support the human and economic activities associated with surrounding land uses" in order to "serve the ... mobility, safety, access, and place-making functions of the public right-of-way" (p. 10). This approach heeds the advice given by d'Ieteren, et al. (2002) on "maintaining a holistic and integrated perspective" in designing streets toward sustainability (p. 13). Figure 3 below shows the key topics, issues, or variables in the planning and design of active, sustainable streets.

Figures 4 through 6 reveal how street purposes are balanced on three arterial street archetypes. The first archetype is the sustainable arterial street, which serves an array of purposes and offers transport choices to street users. As Figure 4 depicts schematically, transport does not dominate this type of street, as there is ample space for commercial, socio-cultural, and recreational purposes. In contrast, the purposes served by the conventional arterial streets common in North America, which are shown schematically in Figure 5, lack balance. This type of street is domi-



Figure 3. Attributes for Assessment of Active, Sustainable Arterial Streets

nated by the transport task, mostly in the form of movement of private motor vehicles. Figure 6 shows the extreme imbalance in an arguably pathological form of the conventional arterial street also common in North America, the "sewers for the rapid movement of lumps of metal"

(Whitelegg, 2011, p. 3). These illustrations reflect in abstract form right-of-way space allocation. They are also an abstract measure of the dominance of the motor vehicle.

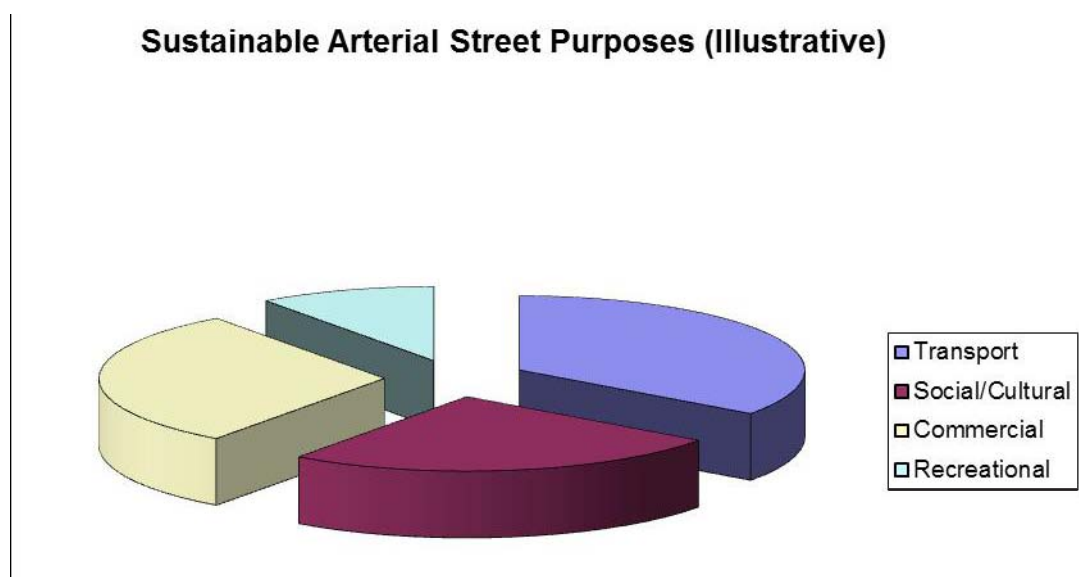

Figure 4. Street Purpose Distribution of an Archetypal Sustainable Arterial Street

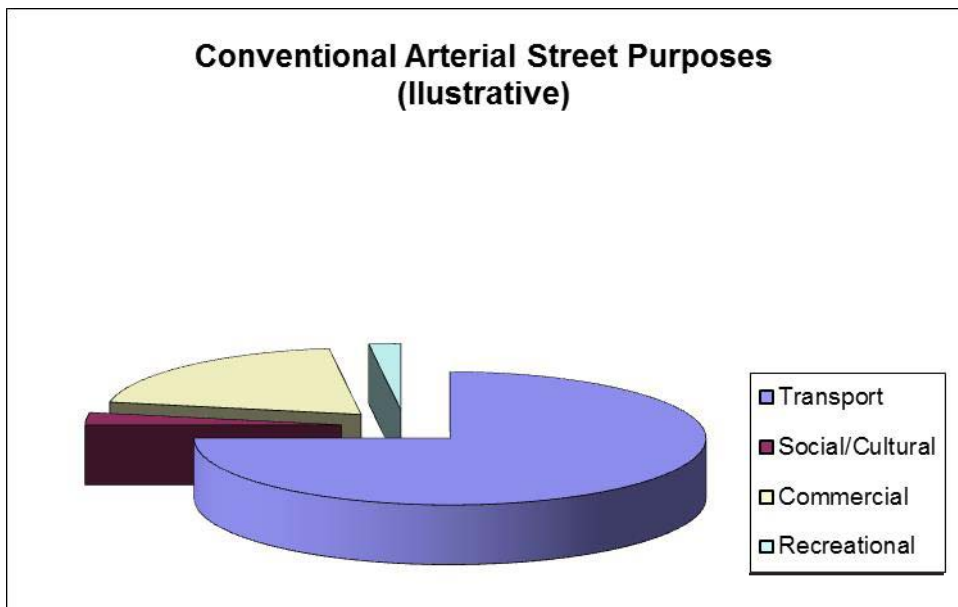

Figure 5. Street Purpose Distribution of an Archetypal Conventional Arterial Street

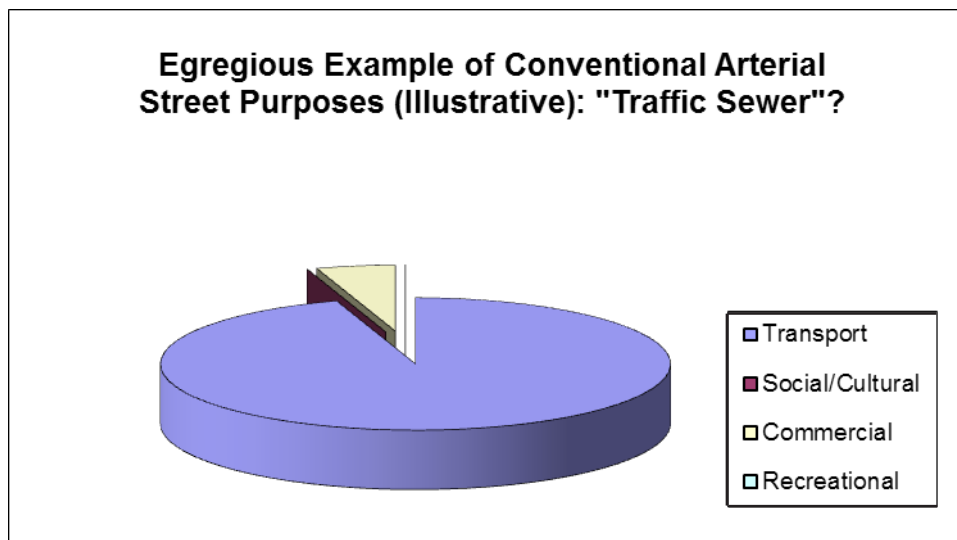

Figure 6. Street Purpose Distribution of an Archetypal Traffic Sewer Arterial Street

6. Streets of tomorrow: The new norms of sustainable street design

A new and more sustainable set of norms for street design has emerged in recent years. In North America, the Urban Street Design Guide, published by the National Association of City Transportation Officials (NACTO) in 2013, has set a new standard for creating livable, sustainable streets (NACTO, 2013). This street design manual sets forth standards that create a safer, more comfortable place for pedestrians and cyclists within the street right of way while reducing motor vehicle space allocation and speed. In the companion Urban Bikeway Design Guide, NACTO sets forth

guidance on effective accommodation for the bicycle, a travel mode emerging as a competitor to the car for shorter trips in many North American cities (NACTO, 2014). NACTO has promulgated these standards nationwide, including at national Designing Cities conferences held in Austin, Texas in 2015 and upcoming this September in Seattle, Washington. State (California State Transportation Agency 2015) and federal (Federal Highway Administration, 2014) design standards in the US have been revised to reflect some of the new thinking by NACTO on street design.

Vision Zero, a multi-national road safety initiative that began in Sweden in 1996,

has also taken hold in North America. In New York City, San Francisco, and other urban areas Vision Zero efforts are focused on traffic calming and safer streets for pedestrians and bicyclists. These measures mesh well with NACTO guidance, thus have provided added impetus for changing street design norms.

An emergent paradigm of placemaking for cities and suburbs has given powerful reinforcement to the new norms of street design. The New York based Project for Public Spaces (PPS) has lead the way in facilitating plaza and street re-design throughout North America and internationally. PPS promulgates the doctrine of streets and squares as important public spaces in which life on foot should have precedence over life behind the wheel of private motor vehicles. In this work, PPS is closely aligned with contemporary thought in urban design (Gehl, 2010) and as well older anti-modernist thinking about the importance of designing cities for people, not motor vehicles. (J. Jacobs, 1961).

7. Conclusion

As what occurs on streets takes place at the junction of the physical and the behavioral, complexity is practically pre-ordained. There is an expansive, multidisciplinary literature on sustainable, active streets. A sense or thread in much of this literature on the streets, to borrow the title of an article by the American urban designer Elizabeth Macdonald (2007), is of the street as "wasted space, potential place". There seems little doubt that streets have had and continue to have an important role in the life of cities and those who live in cities. Streets clearly have potential to contribute to urban sustainability. This potential reflects the distance to be covered from the often disappointing actuality of contemporary streets to their bright, shining possible future as sustainable, active public spaces.

Just as sustainability is more an elusive ideal than an achievable end state, research on the sustainability of streets may progress toward but never arrive at a metaphorical "terminal station". Located at the juxtaposition and responding to

dynamic systems of transportation, land use, urban design, and human behavior, streets themselves will not remain static. The study of streets is therefore necessarily also an inquiry into the evolution of cities and their inhabitants, technology, commerce, leisure, and culture.

New norms for sustainable street design are emerging to make comfort and safety for people on foot or on bicycle the principal aims. This new thinking put an emphasis on streets as places in which much of city life takes place. This in turn has meant reversing steps down the asphalt path toward increased automobile and instead walking and cycling to active, sustainable streets and cities.

Author details:

Joseph Kott, PhD, AICP, PTP
Principal

Transportation Choices for Sustainable Communities Research and Policy Institute
Oakland, CA USA

E-mail:

JKott@trnsportchoice.com

References:

Appleyard, D. (1987). Forward. In A. V. Moudon (Ed.), *Public streets for public use*. New York: Van Nostrand Reinhold.

Appleyard, D., Gerson, M.S., & Lintell, M. (1981). *Livable streets*. Berkeley: University of California Press.

Bradbury, A., Tomlinson, P., & Millington, A. (2007). Understanding the evolution of community severance and its consequences on mobility and social cohesion over the past century. Leiden, The Netherlands: Association for European Transport, European Transport Conference.

Brown, J. (2006). From traffic regulation to limited ways: The effort to build a science of transportation planning. *Journal of Planning History*, 5(1), 3-34.

Caltrans (2015). *Caltrans highway design manual*, (revised 6th edition). Sacramento, CA: California State Transportation Agency.

- Daisa, J.M. (2006). Context sensitive solutions in designing major urban thoroughfares for walkable communities. Washington, DC: Institute of Transportation Engineers, Congress for the New Urbanism, U.S. Department of Transportation, Federal Highway Administration, U.S. Department of Environmental Protection.
- d'Ieteren, E., Morelle, S., & Hecq, W. (2002). Arterial streets toward sustainability: Approach of the sustainability concept, version 1.1: Internal technical note. Bruxelles: Centre for Economic and Social Studies on the Environment, Université Libre de Bruxelles.
- Engwicht, D. (1999). Street reclaiming: Creating livable streets and vibrant communities. Gabriola Island, BC: New Society Publishers.
- Federal Highway Administration. (2014). Manual on uniform traffic control devices for streets and highways with revisions 1 and 2. Washington, D.C.: United State Department of Transportation, Federal Highway Administration.
- Gehl, J. (2006). New city life. Copenhagen: Danish Architectural Press.
- Gehl, J., & Gemzøe, L. (2003). Winning back public space. Burlington, VT: Ashgate.
- Gehl, J. (2010). Cities for people. Washington, D.C.: Island Press.
- Grava, S. (2003). Urban transportation systems: Choices for communities. New York: McGraw-Hill.
- Gunnarsson, S. O. (2004). The pedestrian and the city: A historical review, from the Hippodamian city, to the modernist city and to the sustainable and walking-friendly city. Copenhagen: Walk 21-V Conference on Cities for People. Retrieved from <http://www.walk21.com/conferences/copenhagen.asp>
- Hawkes, A., & Sheridan, G. (2009). Rethinking the street space: Toolkits and street design manuals. Planetizen. Retrieved from <http://www.planetizen.com/node/40394>
- Hebbert, M. (2005). Engineering, urbanism and the struggle for street design. *Journal of Urban Design*, 10(1), 39-59.
- Hess, P. M. (2009). Avenues or arterials: The struggle to change street building practices in Toronto, Canada. *Journal of Urban Design*, 14(1), 1-28.
- Jacobs, A. B. (1993). Great streets. Cambridge, MA: MIT Press.
- Jacobs, J. (1961). The death and life of great American cities. New York: Random House.
- Jones, P., Boujenko, N., & Marshall, S. (2007a). Link & place: a guide to street planning and design. London: Local Transport Today Ltd.
- Jones, P., Roberts, M., & Morris, L., (2007b). Rediscovering mixed-use streets: The contribution of local high streets to sustainable communities. Bristol: Published for the Joseph Rowntree Foundation by The Policy Press.
- Kostof, S. (1992). The street. In S. Kostof, G. Castillo, & R. Tobias (Eds.), *The city assembled*:
- Kott, J. (2012). Streets of clay: design and assessment of sustainable urban and suburban streets. [Doctoral dissertation]. Retrieved from http://espace.library.curtin.edu.au/R?func=dbin-jump-fu-ll&local_base=gen01-era02&object_id=171640
- Kubilins, M. A. (1999, June). Designing functional streets that contribute to our quality of life. Proceedings of the 1st Urban Street Symposium: My Street, Our Street – Developing Livable Transportation Solutions. Dallas, TX: Transportation Research Board. Retrieved from http://www.urbanstreet.info/1st_symp_proceedings/Ec019_b3.pdf
- Lillebye, E. (2007). The street as extended road notion: The architectural and functional significance of the street as a social arena. [Doctoral Dissertation.] Retrieved from <http://ntnu.diva-portal.org/smash/record.jsf?pid=diva2:122484>

- Lynch, K. (1960). *The image of the city*. Cambridge MA: Technology Press.
- Macdonald, E. (2007). *The future metropolitan landscape - Section 1 - Wasted and reclaimed landscapes - Wasted space/potential place: Reconsidering urban streets*. *Places*, 19(1), 22-27.
- Marshall, S. (2003). *The street: Integrating transport and the urban environment*. In K. J. Button & D. A. Hensher (Eds.), *Handbook of transport and the environment: Handbooks in transport*, 4. Oxford: Elsevier.
- Marshall, S. (2005). *Streets & patterns*. New York: Spon Press.
- Marshall, S. (2009). *Cities design and evolution*. New York: Routledge.
- Marshall, S., Jones, P., & Plowright, I. (2004). *A framework for classification and assessment of arterial streets*. (Report D1 to the ARTISTS Consortium). Retrieved from http://home.wmin.ac.uk/transport/download/ARTISTS_D1.pdf
- McShane, C. (1994). *Down the asphalt path: the automobile and the American city*. New York: Columbia University Press.
- Mehta, V. (2006). *Lively streets: Exploring the relationship between built environment and social behavior*. [Doctoral Dissertation.] Retrieved from <http://hdl.handle.net/1903/4165>
- Moule, E, & Polyzoides S. (1994). *The street, the block, and the buildings*. In P. Katz (Ed.), *The new urbanism: Toward an architecture of community*. New York: McGraw-Hill.
- National Association of City Transportation Officials. (2013). *Urban street design guide*. Washington, D.C.: Island Press
- National Association of City Transportation Officials. (2014). *Urban bikeway design guide (2nd ed.)*. Washington, D.C. National Association of City Transportation Officials.
- Rykwert, J. (1986). *The street: The use of it's history*. In S. Anderson (Ed.), *On Streets*. Cambridge, MA: MIT Press.
- Svensson, Å. (Ed.). (2004). *Arterial streets for people: Guidance for planners and decision makers when reconstructing arterial streets*. Lund, Sweden: Lund University.
- Whitelegg, J. Editorial. (2011). *World Transport Policy & Practice*, 17.2, 3.

The Public City.

Essays in honour of Paul Mees,

edited by Brendan Gleeson and Beau B Beza, Melbourne University Press, 2014
ISBN 9780522867305

Reviewed by John Whitelegg

Paul Mees was a good friend and a contributor to this journal. More importantly he brought a very rare collection of talents to the world of sustainable transport and the possibility that one day soon we could have an intelligent, ethical, child-friendly attractive arrangement of cities and transport choices. His distinctive mixture of academic rigour, writing skills, campaigning ability, media skills, debating skills and humour was much needed, highly effective and is now much missed. Paul died on 19 June 2013 at the age of 52. His writings and distinctive contribution to the shaping of debate and arguments about city shaping, urban space, mobility and public transport is splendidly captured in this book. His insights into the deeply flawed ideologies that still drive transport and urban planning in Australia and the UK are more relevant than ever but we have no excuses for not building on the solid foundations he has prepared for the struggles yet to come. Paul understood that privatisation, fragmentation, raw capitalism and neo-liberalism were corrosive and disruptive elements in urban and transport planning and would never produce a high quality living environment that could serve the needs of all social groups, ages and both genders. The editors of this collection of essays summarise the "Meesian" approach as promoting "The Public City" and that is a strong, visionary and visual image that we would all be well advised to keep uppermost in our thinking, willing and doing.

The book rather unsurprisingly reflects Paul's wide ranging knowledge, intellectual depth and eclecticism. It has 16 chapters divided into 4 sections: public urbanist; urban publics; public movement and urban governance.

The book is full of Meesian gems that are too numerous to list. I like the summary of Melbourne's dalliance with the privatisation of urban public transport (p45). It was a disaster. His critique of the ridiculous East-West Link in Melbourne memo-

rably and movingly beamed into a conference at Fitzroy Town Hall a matter of days before his death is masterly and could be applied to many of the grandiose, pompous road building projects going ahead around the world at eye-wateringly high costs and with no gains in congestion relief or the health impacts of air pollution.

One of Mees's main contributions to a rather fraught debate in Australia (Density v destiny) was very important indeed. He demonstrated that urban densification as a primary goal of urban and transport policy misses the main point around the design and delivery of a high quality public transport system. A high density can help to improve walking, cycling and public transport efficiency but the main things that need to be done are in the areas of network design, integration and operational issues (pages 145/146). The density v destiny debate is complicated but Paul Mees could not have been clearer. We can have excellent public transport in areas normally thought of as incapable of supporting excellent public transport e.g. low density suburbs around the periphery of many Australian cities and small towns and villages in rural areas e.g. Trüllikon in Switzerland (page 155). Trüllikon is low density, small village and contrary to received "wisdom" in Australia and the UK supports a frequent bus service and high quality links to railway stations and service centres. This would come as a shock to many UK planners and politicians who are totally committed to the idea that rural residents must have a car and the car is the desirable option for making contact with everyday destinations. This is not correct and Paul Mees was an expert at pointing out the flaws and prejudices in the arguments and decisions of politicians.

"The Public City" should be standard reading for everyone involved in transport and urban planning. It tells such a good story in a very readable fashion and leads to a very clear conclusion. We can have the kind of city, suburb and public transport system that Paul worked for with such dedication for so many years. His work is still there to inform and enthuse and we must now make sure that we build on his superb contribution to the sustainable transport debate and make sure it happens.